

Electro-Pneumatic Positioner/Smart Positioner

(Lever type / Rotary type)



Dustproof / Waterproof

Passed by external organization on **JIS F8007** (conforms to IEC 60529) **IP65**

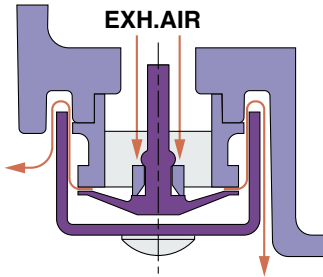

A centralized exhaust system employs the combination of the check valve and the labyrinth effect enhancing both dustproof and waterproof performance.

Monitoring function

Electro-Pneumatic Positioner

- Opening current transmission analogue (4 to 20 mA DC) continuous output

Smart Positioner

- Alarm point output function (2 points)
- Analogue (4 to 20 mA DC) continuous output

With external scale plate (Rotary type)



External scale plate

Improved visibility of opening indicator

Explosion-proof construction

Electro-Pneumatic Positioner	TIIS explosion-proof construction (ExdIIBT5) ATEX intrinsically safe explosion-proof construction (II2G Ex ibIIC T5/T6)
Smart Positioner	ATEX intrinsically safe explosion-proof construction (II1G Ex iaIIC T4/T5/T6)

With internal opening indicator plate (X14 only)



Internal opening indicator plate

Opening indicator plate inside body

Body with LCD window

(Smart Positioner)



LCD window

Allows checking of control from outside body

Electro-Pneumatic Positioner

Universal mechanically controlled type
Series IP8000/8100



IP8000
(Lever type)



IP8100
(Rotary type)

NEW Smart Positioner

Electronically controlled easy-adjustment transmitting type
Series IP8001/8101



IP8001
(Lever type)



IP8101
(Rotary type)

Series IP8



CAT.EUS60-18B-UK

NEW Smart Positioner

Series IP8001/8101 added!

Built-in microcomputer and sensor allows easy remote parameter change and monitoring.

- Internal push button for easy setting of various parameters (Refer to parameter list)
- Zero point/span adjustment easier than with previous mechanical positioners



IP8001 (Lever type)

IP8101 (Rotary type)

Parameter List

Notes	No	Parameter	Description
Standard equipped functions	1	Positive operation/reverse operation setting	Change operation direction with regard to input signal Change to internal components, piping not possible
	2	Split range setting	Change range of input signal
	3	Preferred zero point/span adjustment setting	Change actuator stroke range with regard to input signal
	4	Forced full close/full open setting	To ensure valve closure, force actuator opening to be 0% or 100% with a preferred input signal.
	5	Valve characteristic setting	Select from these 6 valve characteristics Linear characteristic Equality % characteristic (2 types) Quick open characteristic (2 types) User preferred point setting (11 points)
	6	PID constant setting	Change PID constant
	7	Calibration setting	Zero point/span adjustment, Auto PID constant setting, input signal display value calibration, etc.
Optional equipped functions	8	Alarm 1 output setting	Set upper/lower stroke limits for actuator from which alarm is output
	9	Alarm 2 output setting	Set upper/lower stroke limits for actuator from which alarm is output
	10	Analogue (4 to 20 mA DC) output setting	Set increase/decrease direction for 4 to 20 mA DC output with regard to actuator stroke

Full Output Functions

Selecting models with output functions by model selection selects with alarm point output function (2 points) and analogue (4 to 20 mA DC) continuous output function. This will allow remote detection of operating abnormalities.

Control State Display

Positioning, deviation, and input value are displayed (numerically) on the internal LCD, allowing visual verification of the control state.



Display example

Positioning (%)	Input value (%)	Deviation (%)
P 50.0	S 60.0	E 10.0

Handles 2-line Input for Existing Equipment

Control furnished with conventional 2-line input signal (4 to 20 mA DC) not requiring separate power source.

HART Transmission Function

HART transmission function can be designated by model selection. Allows remote monitoring and setting change of positioner.

Intercompatible Installation

Dimensions of mounting parts same as previous mechanical series IP6000/IP8000 Electro-Pneumatic Positioner. External feedback lever and fork lever-type fitting for joining actuator and positioner are also the same.

Energy-saving

Lever-type features 60% reduced air flow consumption compared with IP8000.

Electro-Pneumatic Positioner (Lever type / Rotary type)



Series IP8000/8100

How to Order

ATEX directive compliance and connection

X14	ATEX directive category 2 Intrinsically safe explosion-proof item Air connection port: 1/4 NPT Conduit connection port: M20 x 1.5 With blue cable gland
------------	---

Option Note 9)

Symbol	Option	Applicable model	
		IP8000-X14	IP8100-X14
—	—	●	●
L	Low temperature (-40 to 60°C)	●	●
W	With internal opening indicator plate	—	●

ATEX Directive Intrinsically Safe Explosion proof

Standard

Type

000	Electro-pneumatic lever type
100	Electro-pneumatic rotary type

Pressure gauge

Symbol	Pressure
0	None
1	0.2 MPa
2	0.3 MPa
3	1.0 MPa

Option

CE marking

Q	CE marked product
----------	-------------------

Connection

Symbol	Air	Electric	Applicable model	
			IP8□00-0□0	IP8□00-0□1
—	Rc1/4	G1/2	●	●
M	Rc1/4	M20 x 1.5	●	—
N	Rc1/4	1/2NPT	●	—
1	1/4NPT	G1/2	●	●
2	1/4NPT	M20 x 1.5	●	—
3	1/4NPT	1/2NPT	●	—
4	G1/4	G1/2	●	●
5	G1/4	M20 x 1.5	●	—
6	G1/4	1/2NPT	●	—

Lever type IP8000

Rotary type IP8100

Construction Note 1)

0	1
No terminal box	With terminal box (Exsd2BT5) TIIS (Japan) explosion-proof item

Accessories Note 2)

Symbol	Accessories	Applicable model	
		IP8000	IP8100
—	None (Standard)	●	●
A	ø0.7 Output restriction with pilot valve Note 3)	●	●
B	ø1.0 Output restriction with pilot valve Note 3)	●	●
C	Fork lever-type fitting M Note 4)	—	●
D	Fork lever-type fitting S Note 5)	—	●
E	For stroke 35 to 100 mm with lever unit Note 6)	●	—
F	For stroke 50 to 140 mm with lever unit Note 6)	●	—
G	Compensation spring (A) Note 7)	●	●
H	With external scale plate	—	●
J	With opening current transmission (4 to 20 mA DC)/Positive operation Note 8)	—	●
JR	With opening current transmission (4 to 20 mA DC)/Reverse operation Note 8)	—	●

- Note 1) For construction No.1(with terminal box), the ambient and fluid temperatures are as follows:
 • ExdIIBT5 — -20 to 60°C
 • Non-explosion proof (non hazardous locations only) — -20 to 80°C
 The positioner body is ExdIIBT5 labeled.
- Note 2) If two or more accessories are required, the part numbers should be made according to alphabetical order. (ex. IP8100-011-AG)
- Note 3) "A" is applied to approx 90cm³-capacity actuator.
 "B" is applied to approx 180cm³-capacity actuator.
- Note 4) Fork lever-type fitting MX (Connection thread: M6 x 1) for IP8100-0□0-□-X14.
 Note 5) Fork lever-type fitting SX (Connection thread: M6 x 1) for IP8100-0□0-□-X14.
 Note 6) Standard lever is not attached.
- Note 7) It is to be used together with "A" or "B" when tending to overshoot by the use of "A" or "B".
 It is mounted to the body as a replacement of the standard compensation spring.
- Note 8) Symbol J/JR is with terminal box, non-explosion proof specification. Select 1 for Construction. Positive operation signifies clockwise rotational direction by the main actuator shaft when positioner cover is viewed from the front.
- Note 9) Combination of L and W is not available.

Smart Positioner (Lever type / Rotary type)



Series IP8001/8101

How to Order

ATEX Directive Intrinsically Safe Explosion proof

Standard

Lever type IP8001

Rotary type IP8101

Type

001	Smart lever type
101	Smart rotary type

Pressure gauge

Symbol	Pressure gauge	Applicable model	
		IP8001	IP8101
1	0.2 MPa	●	—
2	0.3 MPa	●	—
3	1.0 MPa	●	●

Specifications

0	Basic type
2	With output function (Analogue (4 to 20 mA DC) output + Alarm output x 2)
3	With HART transmission function

Accessories Note 1)

Symbol	Accessories	Applicable model	
		IP8001	IP8101
—	None (Standard)	●	●
C	Fork lever-type fitting M	—	●
D	Fork lever-type fitting S	—	●
E	For stroke 35 to 100 mm with lever unit <small>Note 2)</small>	●	—
F	For stroke 50 to 140 mm with lever unit <small>Note 2)</small>	●	—
H	With external scale plate	—	●
W	Body with LCD window	●	●

ATEX directive compliance

52 ATEX directive category 1 Intrinsically safe explosion-proof item

ATEX temperature

Symbol	ATEX temperature	Applicable model	
		IP8001	IP8101
—	T4	●	●
T6	T5/T6	●	●

Specifications

4 Intrinsically safe explosion proof (ATEX) + output function + HART transmission function

CE marking

Q CE marked product

Connection

Symbol	Air	Electric
—	Rc1/4	G1/2
M <small>Note)</small>	Rc1/4	M20 x 1.5
N	Rc1/4	1/2NPT
1	1/4NPT	G1/2
2 <small>Note)</small>	1/4NPT	M20 x 1.5
3	1/4NPT	1/2NPT
4	G1/4	G1/2
5 <small>Note)</small>	G1/4	M20 x 1.5
6	G1/4	1/2NPT

Note) When the symbol is M, 2, or 5 for 52-ATEX directive items, a blue cable gland is included with the electrical connection.

Specifications Note 1)

Item	Type	IP8000	IP8100	IP8001	IP8101
		Electro-Pneumatic Positioner		Smart Positioner	
		Lever type lever feedback		Rotary type cam feedback	
		Single action	Double action	Single action	Double action
Input current	4 to 20 mA DC (Standard) <small>Note 2)</small>				
Min. operating current	—		3.85 mA DC or more		
Intra-terminal voltage	—		12 V DC (equivalent to 600 Ω input resistance, at 20 mA DC)		
Max. supplied power	—		1 W (Imax: 100 mA DC, Vmax: 28 V DC)		
Input resistance	235 ±15 Ω (4 to 20 mA DC)		—		
Supply air pressure	0.14 to 0.7 MPa				0.3 to 0.7 MPa
Standard stroke	10 to 85 mm (Allowable deflection angle 10 to 30°)	60 to 100° <small>Note 3)</small>		10 to 85 mm (Allowable deflection angle 10 to 30°)	60 to 100° <small>Note 3)</small>
Sensitivity <small>Note 4)</small>	Within 0.1% F.S.	Within 0.5% F.S.		Within 0.2% F.S.	
Linearity <small>Note 4)</small>	Within ±1% F.S.	Within ±2% F.S.		Within ±1% F.S.	
Hysteresis <small>Note 4)</small>	Within 0.75% F.S.	Within 1% F.S.		Within 0.5% F.S.	
Repeatability <small>Note 4)</small>	Within ±0.5% F.S.				
Coefficient of temperature	Within 0.1% F.S./°C			Within 0.05% F.S./°C	
Supply pressure fluctuation	Within 0.3% F.S./0.01 MPa			— <small>Note 5)</small>	
Output flow <small>Note 6)</small>	80 ℓ/min (ANR) or more (SUP = 0.14 MPa)		200 ℓ/min (ANR) or more (SUP = 0.4 MPa)		
Air consumption <small>Note 6)</small>	5 ℓ/min (ANR) or less (SUP = 0.14 MPa) 11 ℓ/min (ANR) or less (SUP = 0.4 MPa)		2 ℓ/min (ANR) or less (SUP = 0.14 MPa) 4 ℓ/min (ANR) or less (SUP = 0.4 MPa)		11 ℓ/min (ANR) or less (SUP = 0.4 MPa)
Ambient and fluid temperature	General structure: -20 to 80°C				
	TIIS explosion-proof: -20 to 60°C ATEX intrinsically safe explosion-proof: -20 to 80°C (T5) -20 to 60°C (T6) -40 to 60°C (T6)/-L type low-temperature specification			ATEX intrinsically safe explosion-proof -20 to 80°C (T4/T5) -20 to 60°C (T6)	
Explosion proof construction <small>Note 7)</small>	TIIS explosion-proof construction (ExdIIBT5) ATEX intrinsically safe explosion-proof construction (II2G Ex ibIIC5/T6)			ATEX intrinsically safe explosion-proof construction (II1G Ex iaIIC4/T5/T6)	
ATEX intrinsically safe explosion-proof parameter (current circuit)	Ui ≤ 28 V, li ≤ 125 mA, Pi ≤ 1.2 W, Ci ≤ 0 nF, Li ≤ 0 mH			Ui ≤ 28 V, li ≤ 100 mA, Pi ≤ 0.7 W, Ci ≤ 12.5 nF, Li ≤ 1.5 mH	
Exterior covering enclosure	JISF8007, IP65 (conforms to IEC Pub.60529)				
Transmission method <small>Note 7)</small>	—			HART transmission	
Air connection port <small>Note 8)</small>	Rc 1/4 female thread, NPT 1/4 female thread, G 1/4 female thread				
Electrical connection port <small>Note 8)</small>	G 1/2 female thread, M20 x 1.5 female thread, NPT 1/2 female thread				
Material/coating	Aluminum diecast body/baking finish with denatured epoxy resin				
Weight	2.4 kg (Without terminal box)/2.6 kg (With terminal box)			2.6 kg	

Note 1) Specification values are given at normal temperature (20°C).

Note 2) 1/2 Split range (Standard)

Note 3) Stroke adjustment: 0 to 60°, 0 to 100°

Note 4) Characteristics relating to accuracy differ depending on combination with other constituent loop equipment, such as positioners and actuators.

Note 5) While there is no output changes due to pressure fluctuations, when the pressure supply setting is changed following calibration, once again adjust balance current and perform calibration.

Note 6) (ANR) indicates JIS B0120 standard air.

Note 7) Model selection required for explosion proof construction and HART transmission.

Note 8) Thread type can be specified by model selection.

Optional Specifications

Item	Type	IP8100-0 1-J/JR (Non-explosion proof)	IP8 01-0 2	52-IP8 01-0 4
		Electro-Pneumatic Positioner	Smart Positioner	
Analogue output	Wiring	2-line		
	Output signal	4 to 20 mA DC		
	Power supply voltage	12 to 35 V DC	10 to 28 V DC	
	Load resistance	(Power supply voltage -12 V) ÷ 20 mA DC or less	0 to 750 Ω	
	Accuracy	±2% F.S. or less <small>Note 1)</small>	±0.5% F.S. or less <small>Note 2)</small>	
	Hysteresis	Within 1% F.S.	—	
Alarm output 1, 2	Wiring	2-line		
	Applicable standards	—	—	DIN19234/NAMUR Standard
	Power supply voltage	—	10 to 28 V DC	5 to 28 V DC
	Load resistance	—	10 to 40 mA DC	(Constant current output)
	Alarm ON	—	R = 350 Ω ±10%	≥ 2.1 mA DC
	Alarm OFF (Leakage current)	—	0.5 mA DC or less	≤ 1.2 mA DC
Response time	—	50 msec or less		

Note 1) Indicates analogue output accuracy with respect to actuator angle.

Note 2) Indicates analogue output accuracy with respect to LCD display position value (P value).

Accessory / Option

Pilot valve with output restriction (IP8000 / 8100)

In general, mounting on a small-size actuator may cause hunting. For prevention, a pilot valve with a built-in output restriction is available. The restriction is removable.

Actuator Capacity	Orifice size	Part number	Pilot unit part number	Model selection accessory
90 cm ³	ø0.7	P36801080	P565010-18	A
180 cm ³	ø1	P36801081	P565010-19	B

Note) Output orifice not required for Smart Positioner regardless of actuator capacity.

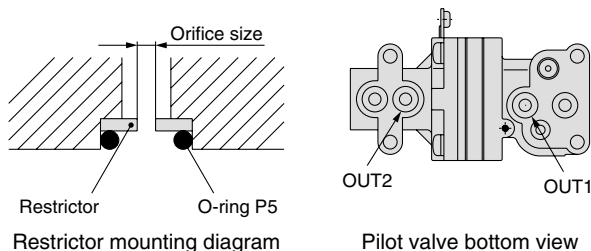

Fork lever-type fittings (IP8100 / 8101)

2 types of rotary type IP8100/8101 fork lever-type fittings, that differ by installation dimensions dependent on bracket installation method, and 2 types of installation portion thread sizes, are available.

When installing on the side surface, using fork lever assembly M provides interchangeability with the installation dimensions of SMC IP6100 positioner. When installing on the rear surface, using fork lever assembly S also provides interchangeability with the installation dimensions of SMC IP6100 positioner.

Part name	Unit number	Installation portion thread size	Model selection accessory
Fork lever assembly M	P368010-24	M8 x 1.25	C
Fork lever assembly S	P368010-25		D
Fork lever assembly MX	P368010-36	M6 x 1	C (Note)
Fork lever assembly SX	P368010-37		D (Note)

Note) Installation portion thread size is M6 x 1 for IP8100-00-X14 when accessory C or D are selected.

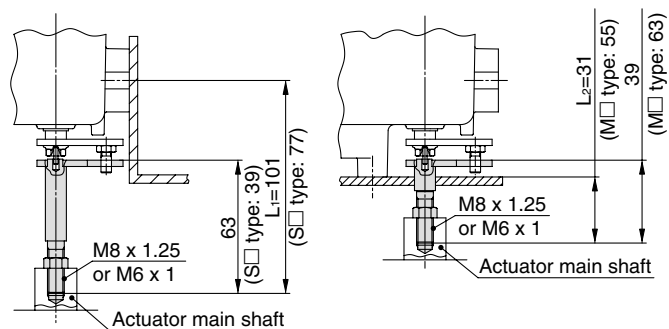

Side mounting with the fork lever assembly M

Rear mounting with the fork lever assembly S

External feedback lever (IP8000 / 8001)

Different feedback levers are available dependent upon valve strokes. Order according to the valve stroke.

Feedback lever types

Stroke	Unit number		Size M	Size N	Model selection accessory
	IP8000	IP8001			
10 to 85 mm	P368010-20	P565010-323	125	150	Standard accessory
35 to 100 mm	P368010-21	P565010-324	110	195	E
50 to 140 mm	P368010-22	P565010-325	110	275	F
6 to 12 mm	P368010-260	P565010-329	75	75	Available as special order

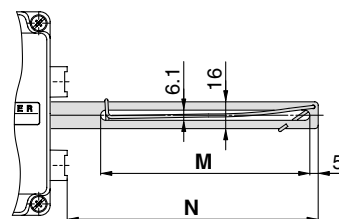

Resin connector (Non-explosion proof specification)

Optional cable connectors are available for different cable sizes. These are not for explosion proof applications. Recommended for use in indoor applications.

Part name	Part number	Suited cable outer diameter
Resin-made cable clamp unit (A)	P368010-26	ø7 to ø9
Resin-made cable clamp unit (B)	P368010-27	ø9 to ø11

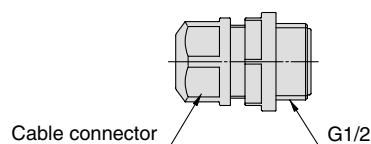

Exploded View

IP8000

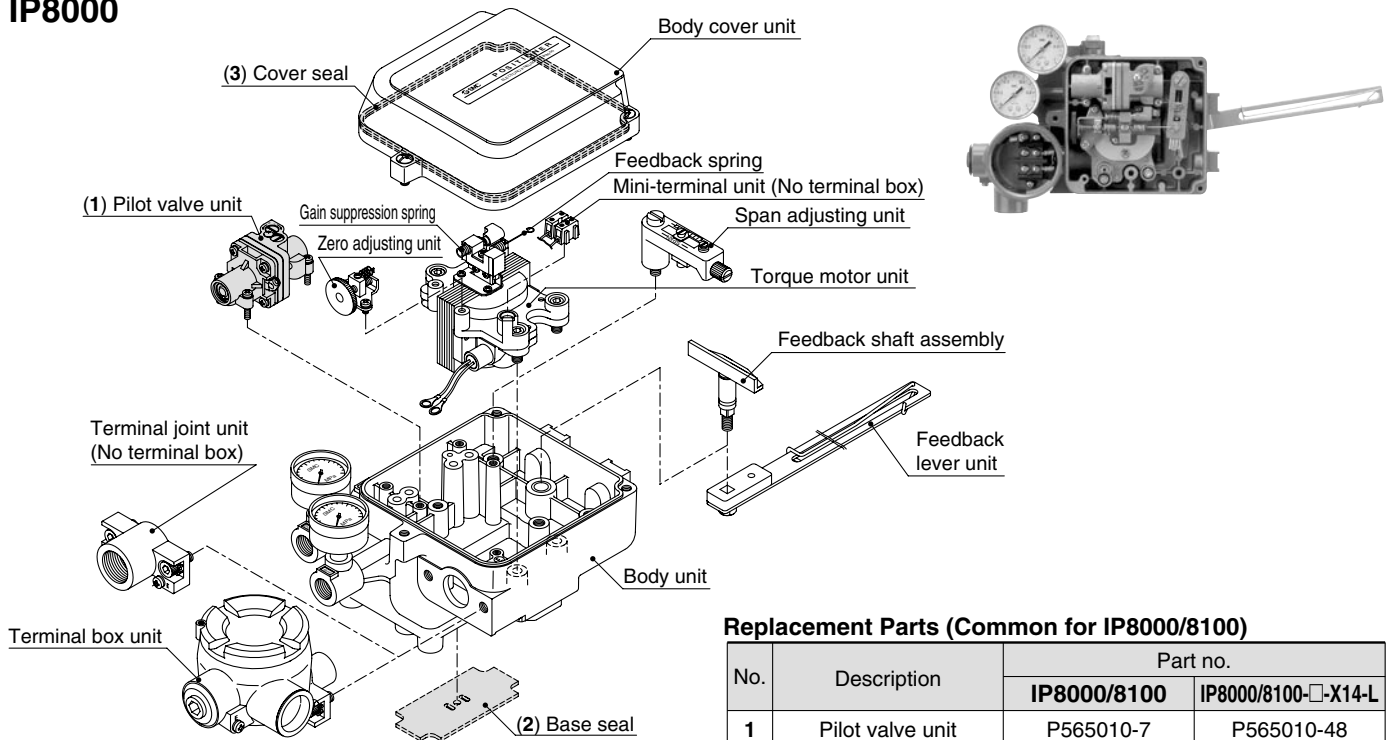

Replacement Parts (Common for IP8000/8100)

No.	Description	Part no.	
		IP8000/8100	IP8000/8100-□-X14-L
1	Pilot valve unit	P565010-7	P565010-48
2	Base seal	P56501012-3	
3	Cover seal	P56501013	

IP8101

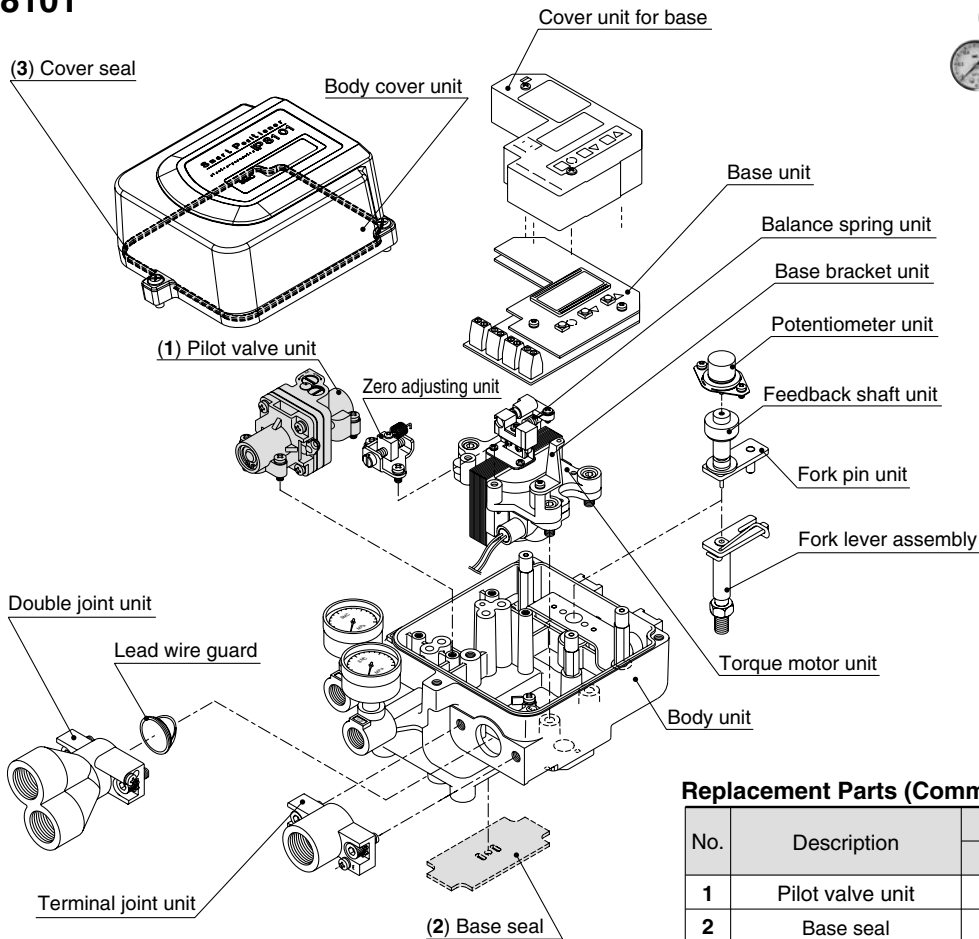

Replacement Parts (Common for IP8001/8101)

No.	Description	Part no.	
		IP8001	IP8101
1	Pilot valve unit	P565010-322	P565010-303
2	Base seal	P56501012-3	
3	Cover seal	P56501013	

Piping Note) When the input signal is discontinued, the pressure of OUT1 decreases, and the pressure of OUT2 increases.

IP8000 / Lever type

	Single action	Double action	
Positive operation	<p>When the input signal is increased, the stem moves as allow mark.</p> <p>OUT2 is plugged.</p>	<p>When the input signal is increased, the stem moves as allow mark. (Positive valve operation by its reverse operation mode)</p> <p>OUT1 is plugged.</p>	<p>When the input signal is increased, the cylinder rod moves as allow mark.</p> <p>Span adjusting lever normal position</p>
Reverse operation	<p>When the input signal is increased, the stem moves as allow mark. (Reverse valve operation by its positive operation mode)</p> <p>OUT1 is plugged.</p>	<p>When the input signal is increased, the stem moves as allow mark.</p> <p>OUT2 is plugged.</p>	<p>When the input signal is increased, the cylinder rod moves as allow mark.</p> <p>Span adjusting lever reverse position</p>

IP8100 / Rotary type

	Single action	Double action	
Positive operation	<p>When the input signal is increased, the actuator shaft rotates in a clockwise direction.</p> <p>OUT2 is plugged.</p> <p>The cam of the positioner should be set on the DA surface.</p>	<p>When the input signal is increased, the actuator shaft rotates in a clockwise direction. (Positive valve operation by its reverse operation mode)</p> <p>OUT1 is plugged.</p> <p>The cam of the positioner should be set on the DA surface.</p>	<p>When the input signal is increased, the actuator shaft rotates in a clockwise direction.</p> <p>OUT1</p> <p>OUT2</p> <p>The cam of the positioner should be set on the DA surface.</p>
Reverse operation	<p>When the input signal is increased, the actuator shaft rotates in a counter clockwise direction. (Reverse valve operation by its positive operation mode)</p> <p>OUT1 is plugged.</p> <p>The cam of the positioner should be set on the RA surface.</p>	<p>When the input signal is increased, the actuator shaft rotates in a counter clockwise direction.</p> <p>OUT2 is plugged.</p> <p>The cam of the positioner should be set on the RA surface.</p>	<p>When the input signal is increased, the actuator shaft rotates in a counter clockwise direction.</p> <p>OUT2</p> <p>OUT1</p> <p>The cam of the positioner should be set on the RA surface.</p>

Piping

Note) When the input signal is discontinued, the pressure of OUT1 decreases, and the pressure of OUT2 increases.
Caution is also similarly required when changing the control direction in parameter mode.

IP8001 / Lever type

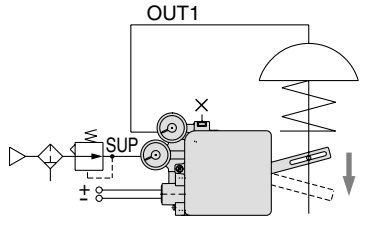
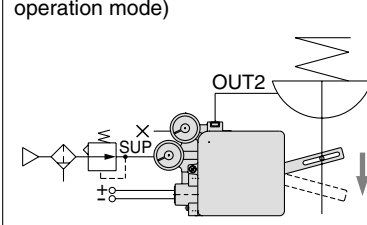
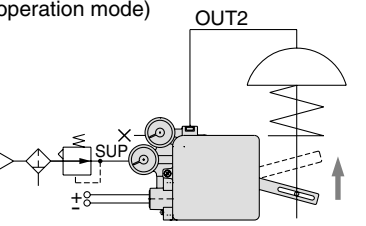
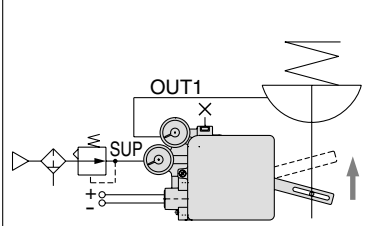
	Single action	Double action
Positive operation	<p>When the input signal is increased, the stem moves as allow mark.</p>  <p>OUT2 is plugged.</p>	<p>When the input signal is increased, the stem moves as allow mark. (Positive valve operation by its reverse operation mode)</p>  <p>OUT1 is plugged.</p>
Reverse operation	<p>When the input signal is increased, the stem moves as allow mark. (Reverse valve operation by its positive operation mode)</p>  <p>OUT1 is plugged.</p>	<p>When the input signal is increased, the stem moves as allow mark.</p>  <p>OUT2 is plugged.</p>

IP8101 / Rotary type

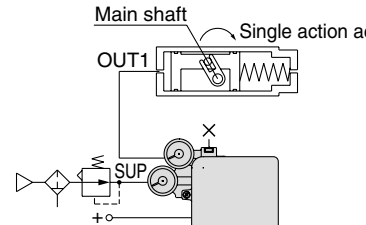
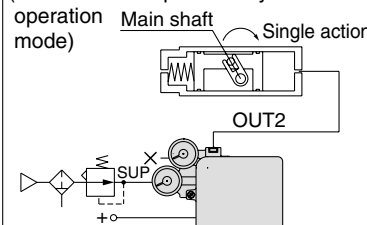
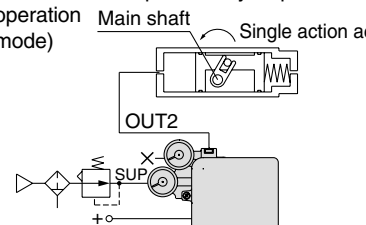
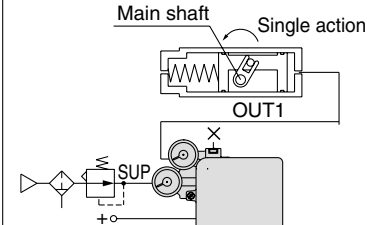
	Single action	Double action
Positive operation	<p>When the input signal is increased, the actuator shaft rotates in a clockwise direction.</p>  <p>OUT2 is plugged.</p>	<p>When the input signal is increased, the actuator shaft rotates in a clockwise direction. (Positive valve operation by its reverse operation mode)</p>  <p>OUT1 is plugged.</p>
Reverse operation	<p>When the input signal is increased, the actuator shaft rotates in a counter clockwise direction. (Reverse valve operation by its positive operation mode)</p>  <p>OUT2 is plugged.</p>	<p>When the input signal is increased, the actuator shaft rotates in a counter clockwise direction.</p>  <p>OUT1 is plugged.</p>

Installation

IP8000/8001 (Lever type)

1. Create brackets that are appropriate for the positioner and diaphragm valve mounting methods, and affix it firmly using the mounting hole on the side or rear surface.

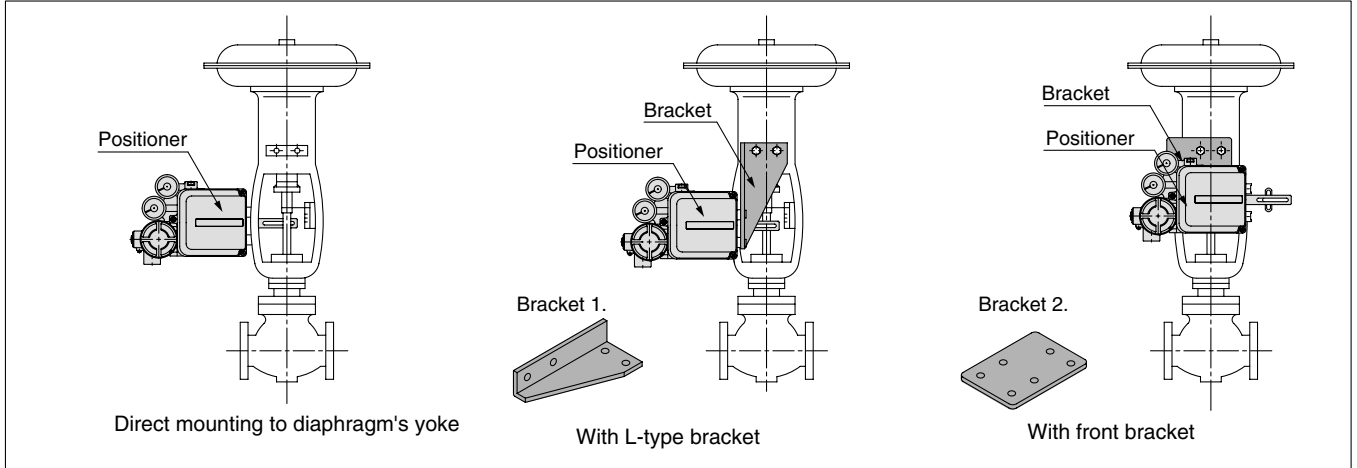

2. The feedback lever that detects the displacement of valve stems should be mounted at a position so that the lever is at right angles to the valve stem for an input current of 50%. The figure is the configuration viewed from the front.

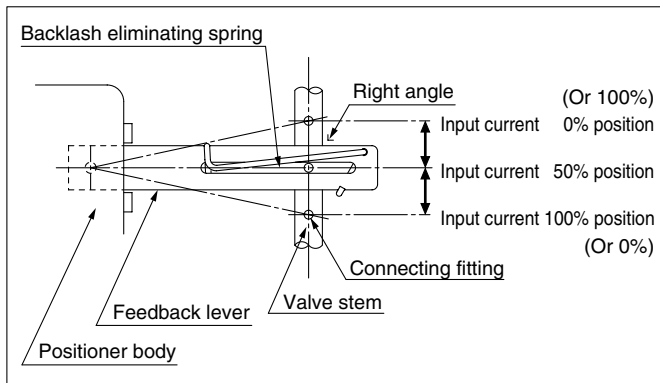

3. Brackets for lever type positioners, which are compliant with NAMUR and DIN/IEC 60534-6-1 are now available.

Description	Part no.
Bracket (NAMUR compliant) single unit	INI-224-0-56
Bracket (NAMUR compliant) kit ^{Note)}	INI-224-0-56-1

Note) Kits that include the bracket (NAMUR compliant) and mounting threads are also available.

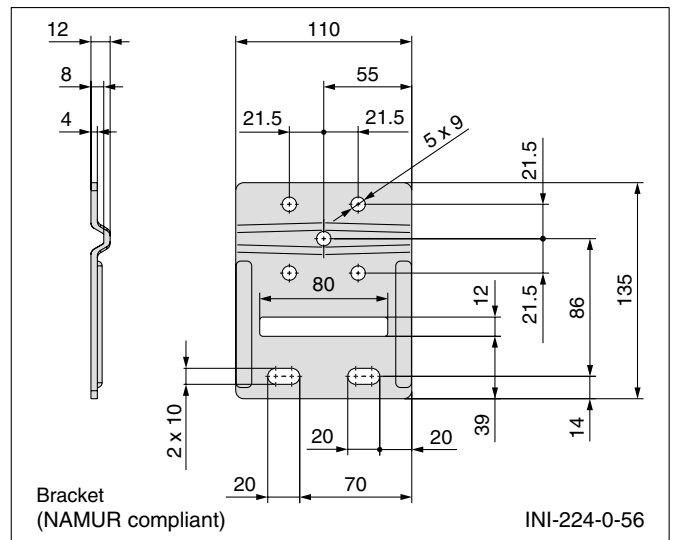

IP8100/8101 (Rotary type)

1. The positioner should be mounted so that the feedback shaft is aligned with the shaft of the rotary actuator.

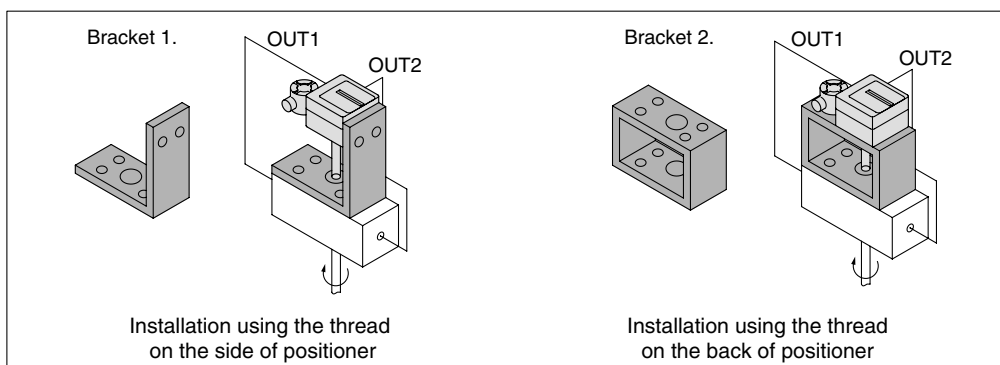

Principle of Operation

IP8000 / Lever type

When the input current increases, (11) the plate spring of (12) the torque motor will work as a pivot, (13) armature will receive a counter clockwise torque, (4) the counter weight will be pushed to the left, the clearance between (6) the nozzle and (5) the flapper will increase, and the nozzle back pressure will decrease. Consequently, (7) the exhaust valve of (1) the pilot valve moves to the right, the output pressure of OUT1 increases and (15) the diaphragm moves downwards. The motion of (15) the diaphragm acts on (10) the feedback spring through (8) the feedback lever, (14) the transmission lever and (9) the span adjustment lever to rest at the balance position generated by the input current. (2) The gain suppression spring is for direct feedback of the motion of (7) the exhaust valve to (4) the counter weight to increase the stability of the loop. The zero point should be adjusted by change of (3) the zero adjustment spring tension.

Single action positive operation

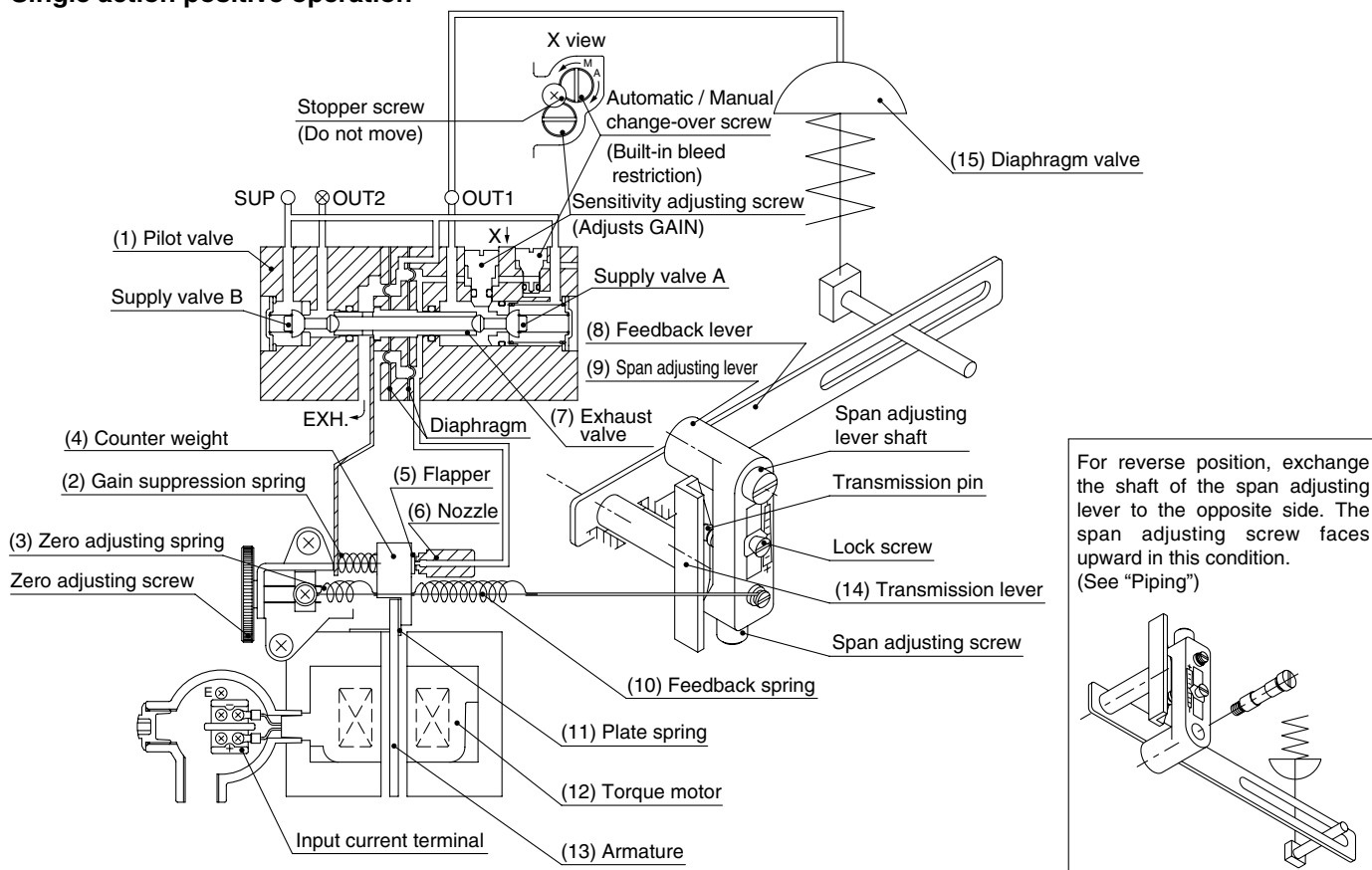

Block diagram

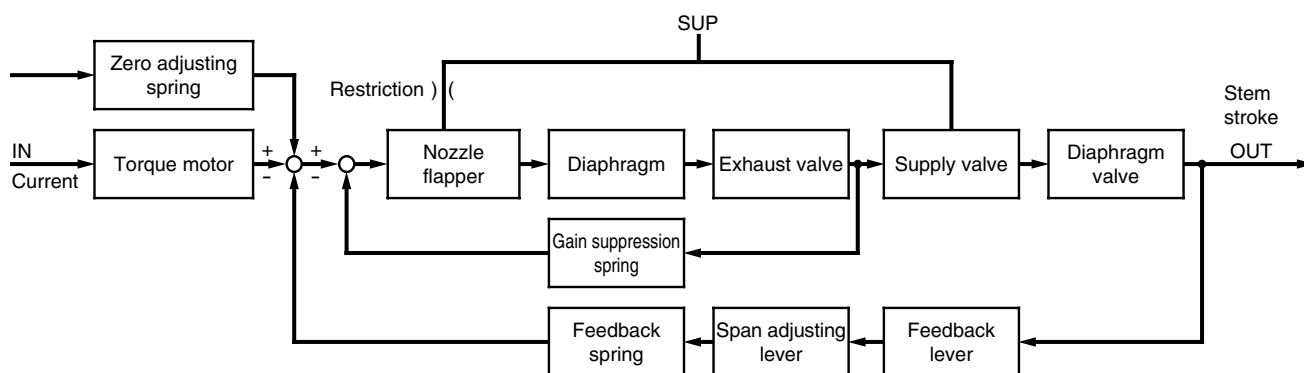

Principle of Operation

IP8100 / Rotary type

When the input current increases, (12) the plate spring of (13) the torque motor will work as a pivot, (14) armature will receive a counter-clockwise torque, (4) the counter weight will be pushed to the left and the clearance between (6) the nozzle and (5) the flapper will increase, and the nozzle back pressure will decrease. Consequently, (7) the exhaust valve of (1) the pilot valve moves to the right, the output pressure of OUT1 increases that of OUT2 decreases and (16) the rotary actuator moves. The motion of (16) the actuator acts on (10) the feedback spring through (11) the feedback shaft, (8) the cam, (9) the span adjustment lever and (15) transmission lever to rest at the balance position generated by the input current. (8) the cam is set on the DA surface and operates positively while (16) the oscillating actuator shaft rotates in a clockwise direction when the input signal is increased. (2) The gain suppression spring is for direct feedback of the motion of (7) the exhaust valve to (4) the counter weight to increase the stability of the loop. The zero point should be adjusted by change of (3) the zero adjustment spring tension.

Double action positive operation

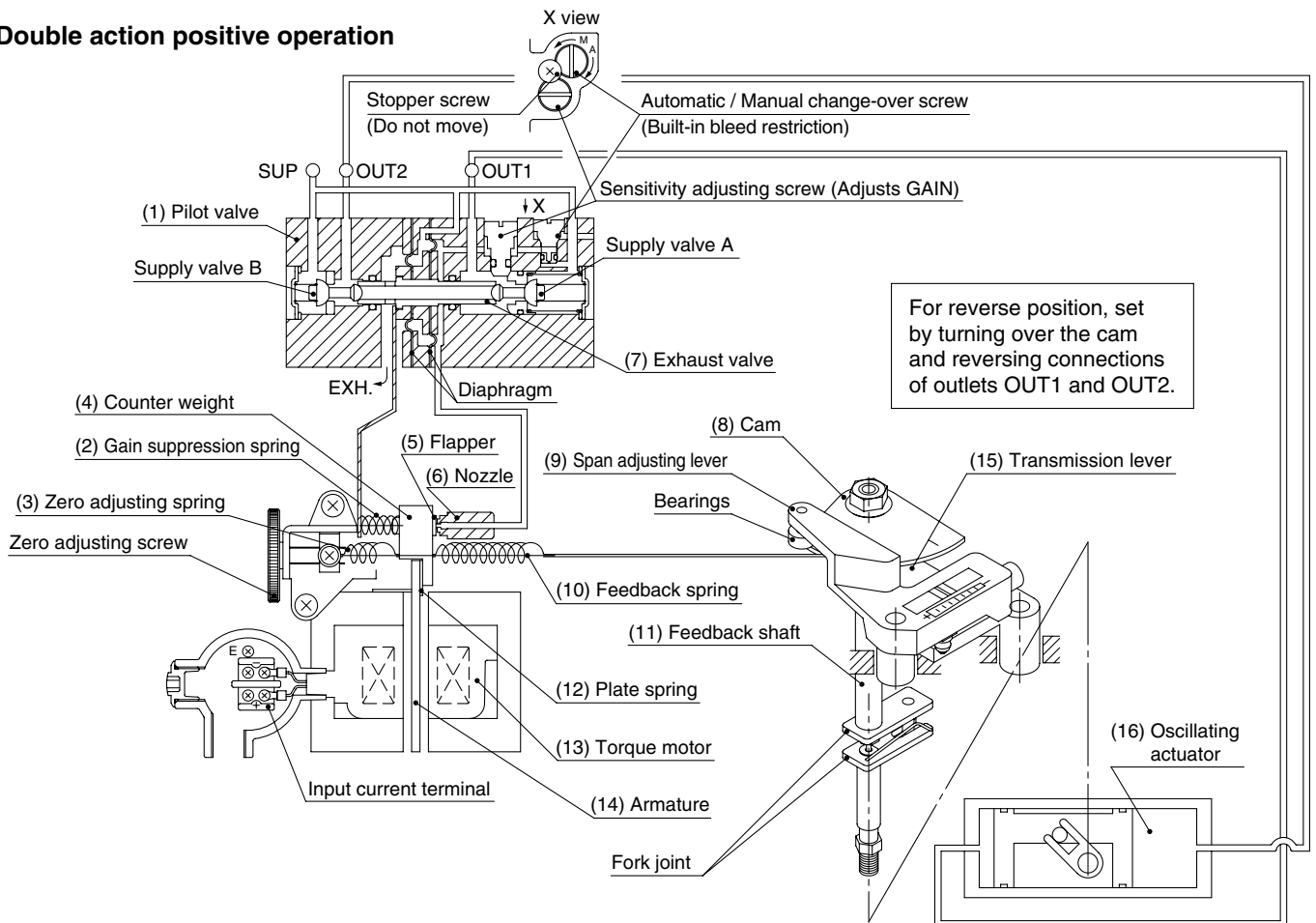

Block diagram

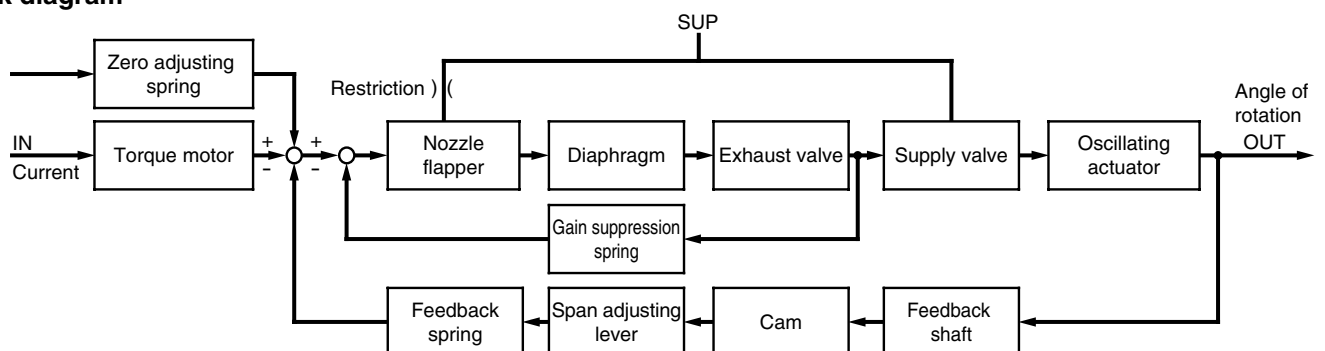

IP8001 / Lever type

When the input current increases, the electrical current inside (12) the torque motor coil will change through (8) the plate's input process, operation process and output process, and (13) the armature will oscillate, with (11) the plate spring as its base. As a result, the clearance between (6) the nozzle and (5) the flapper will increase, and the nozzle back pressure will decrease. Consequently, (7) the exhaust valve of (1) the pilot valve moves to the right, the output pressure of OUT1 increases and causes (15) the diaphragm valve to move. The motion of (15) the diaphragm valve is transmitted to the displacement output process of (8) the board through (14) the feedback lever, (10) the feedback shaft and (9) angle sensor, and the calculated output position will match the input current.

Single action positive operation

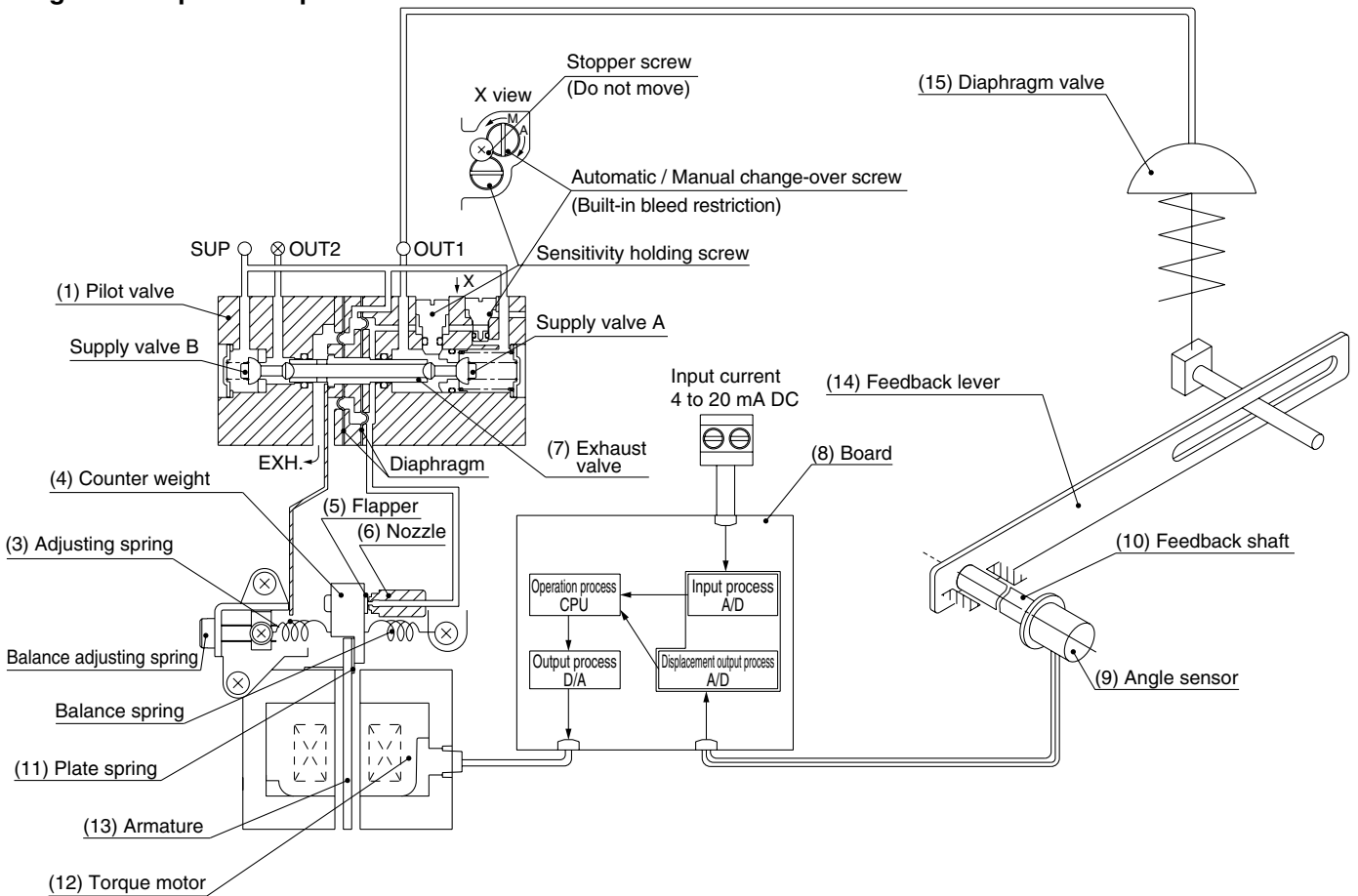

Block diagram

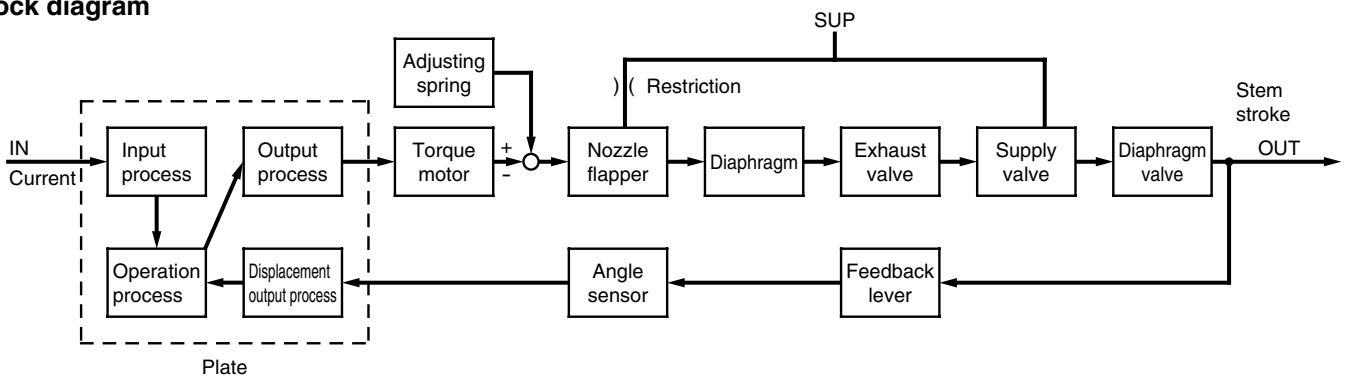

Principle of Operation

IP8101 / Rotary type

When the input current increases, the electrical current inside (12) the torque motor coil will change through (8) the plate's input process, operation process and output process, and (13) the armature will oscillate, with (11) the plate spring as its base. As a result, the clearance between (6) the nozzle and (5) the flapper will increase, and the nozzle back pressure will decrease. Consequently, (7) the exhaust valve of (1) the pilot valve moves to the right, the output pressure of OUT1 increases and causes the output pressure of OUT2 to decrease, causing (14) the oscillating actuator to move. The motion of (14) the oscillating actuator is transmitted to the fork lever-type fitting, (10) the feedback shaft (9) angle sensor, and the displacement output process of (8) the board, and output position will match the input current.

Single action positive operation

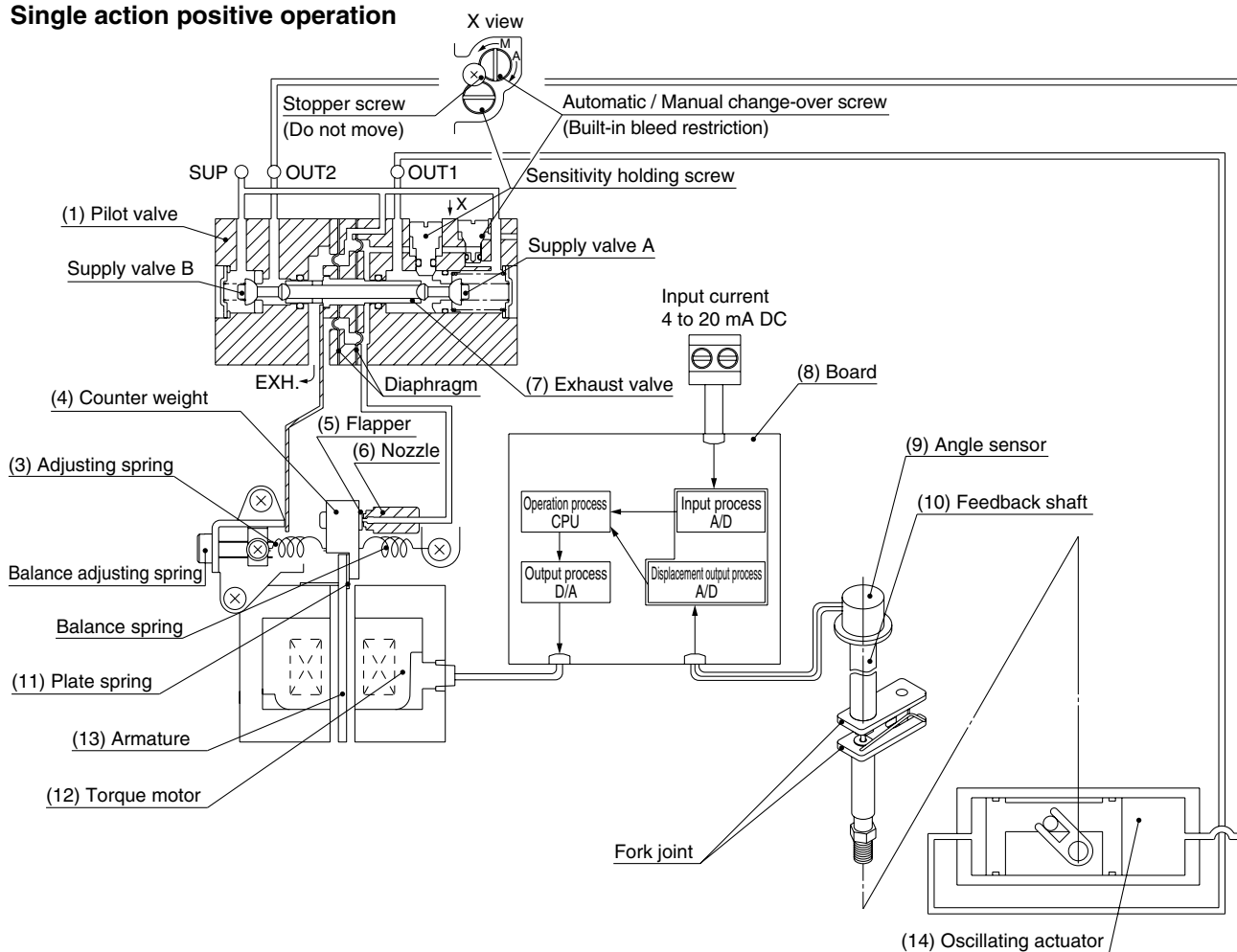

Block diagram

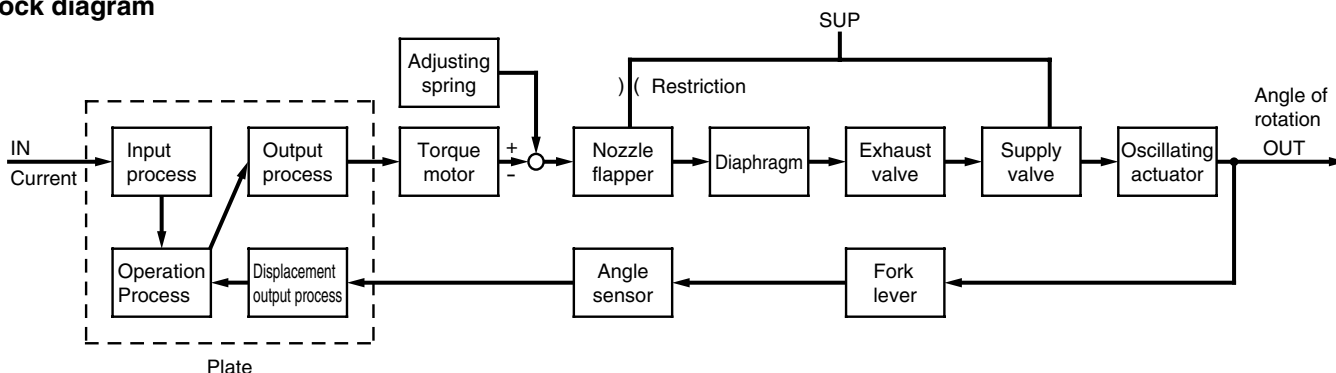

Dimensions / IP8000 (Lever type)

IP8000-0 □ 0 (Without terminal box)

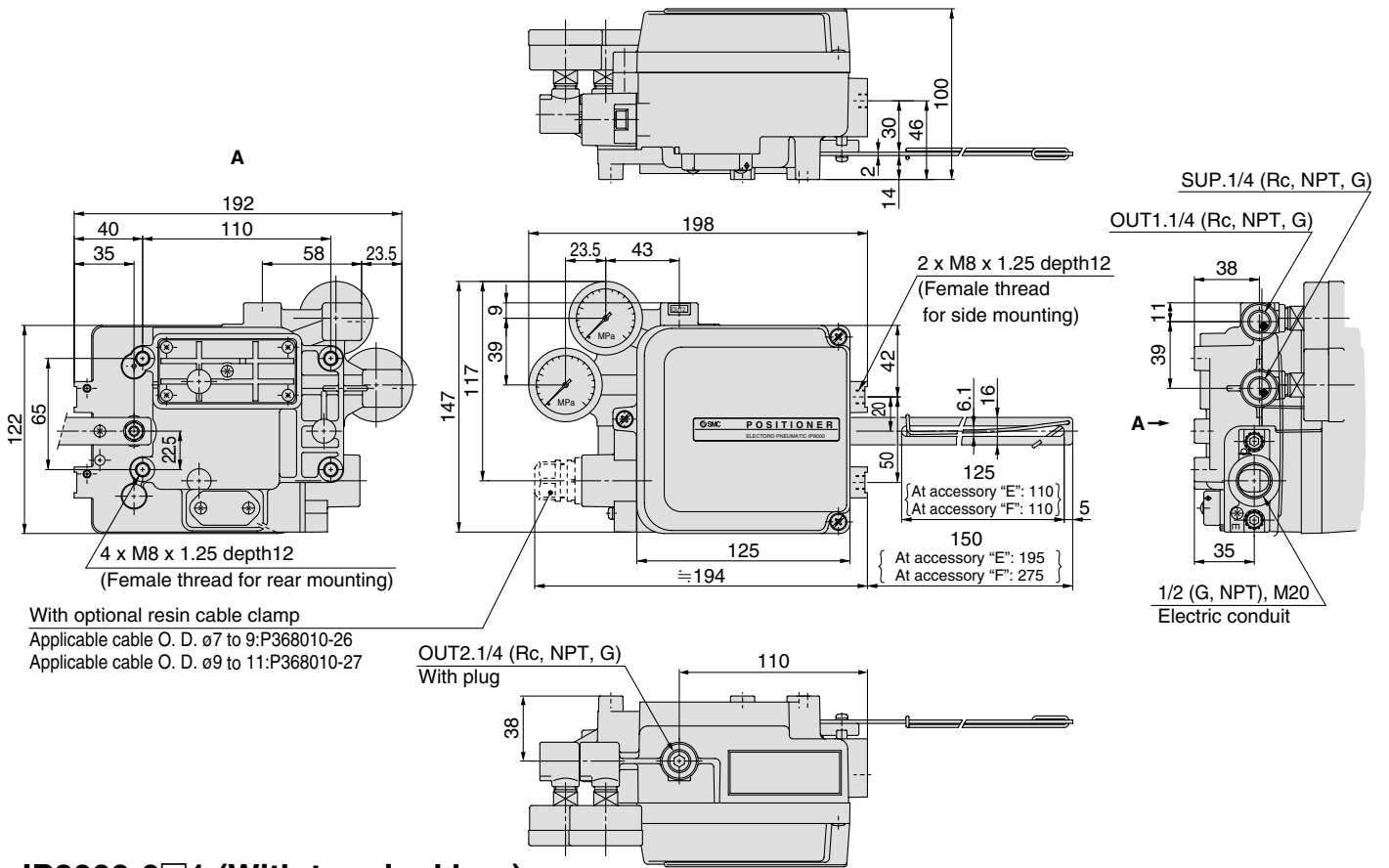

IP8000-0 □ 1 (With terminal box)

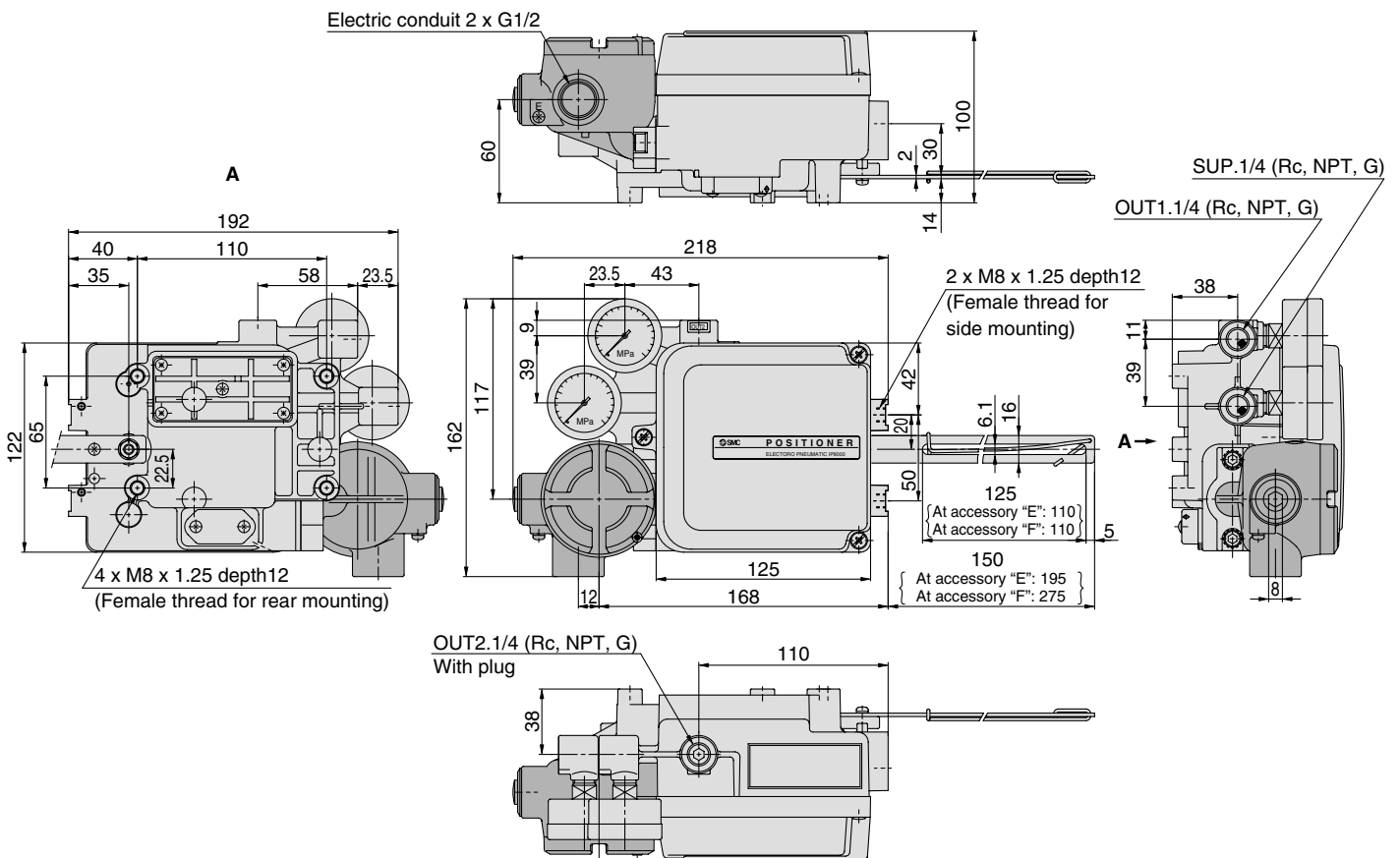

Series IP8

Dimensions / IP8100 (Rotary type)

IP8100-0 0 (Without terminal box)

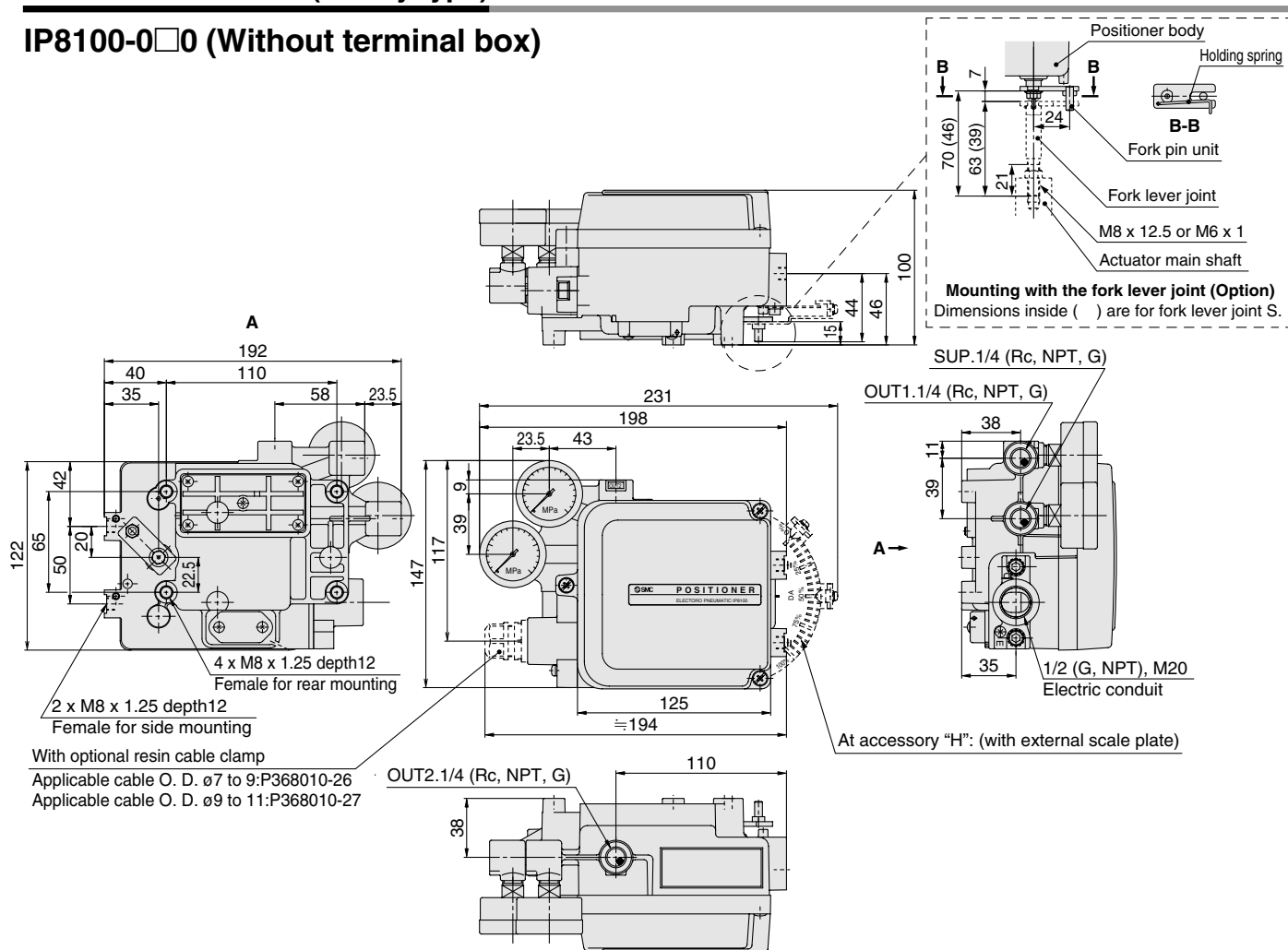

IP8100-0 1 (With terminal box)

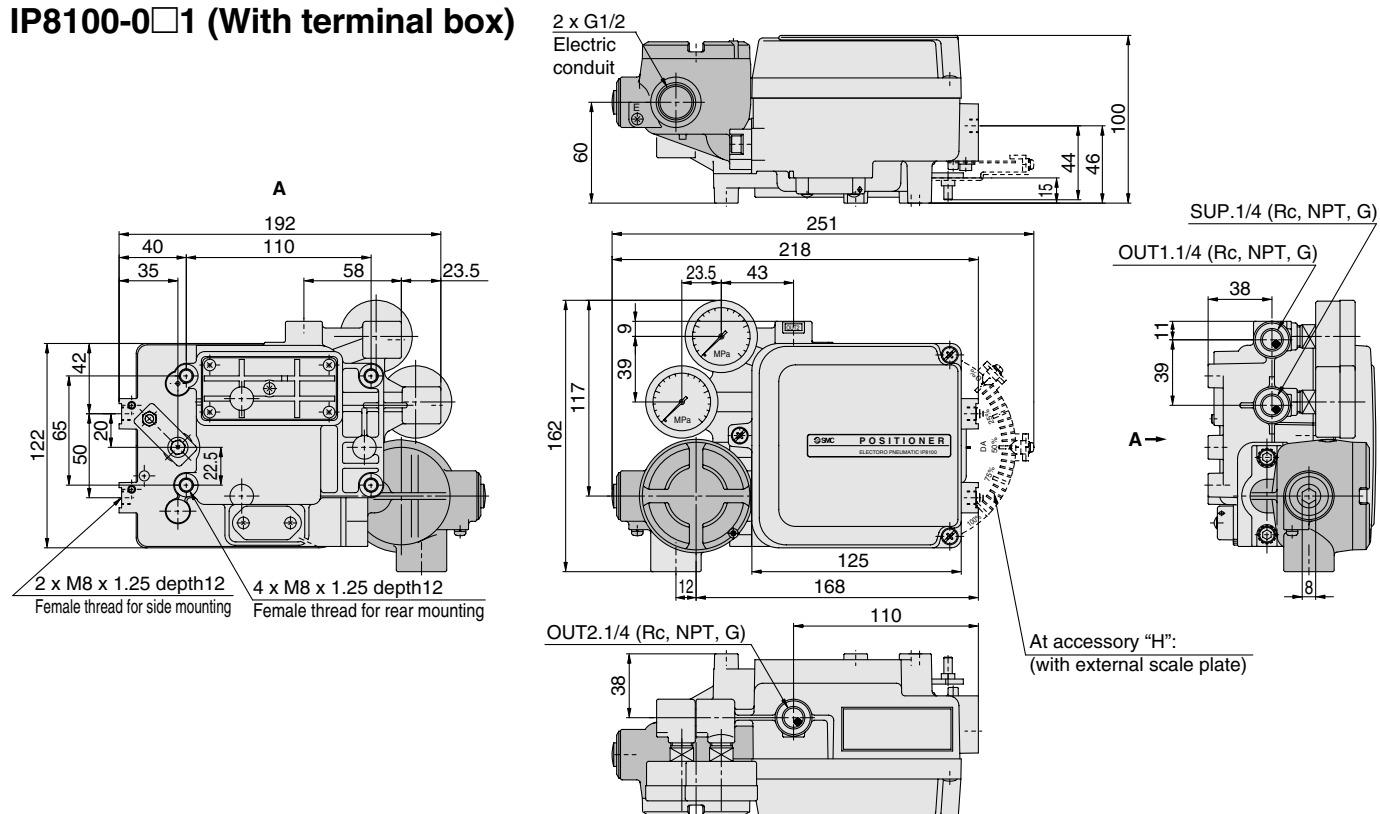

Dimensions / IP8001 (Lever type)

IP8001-

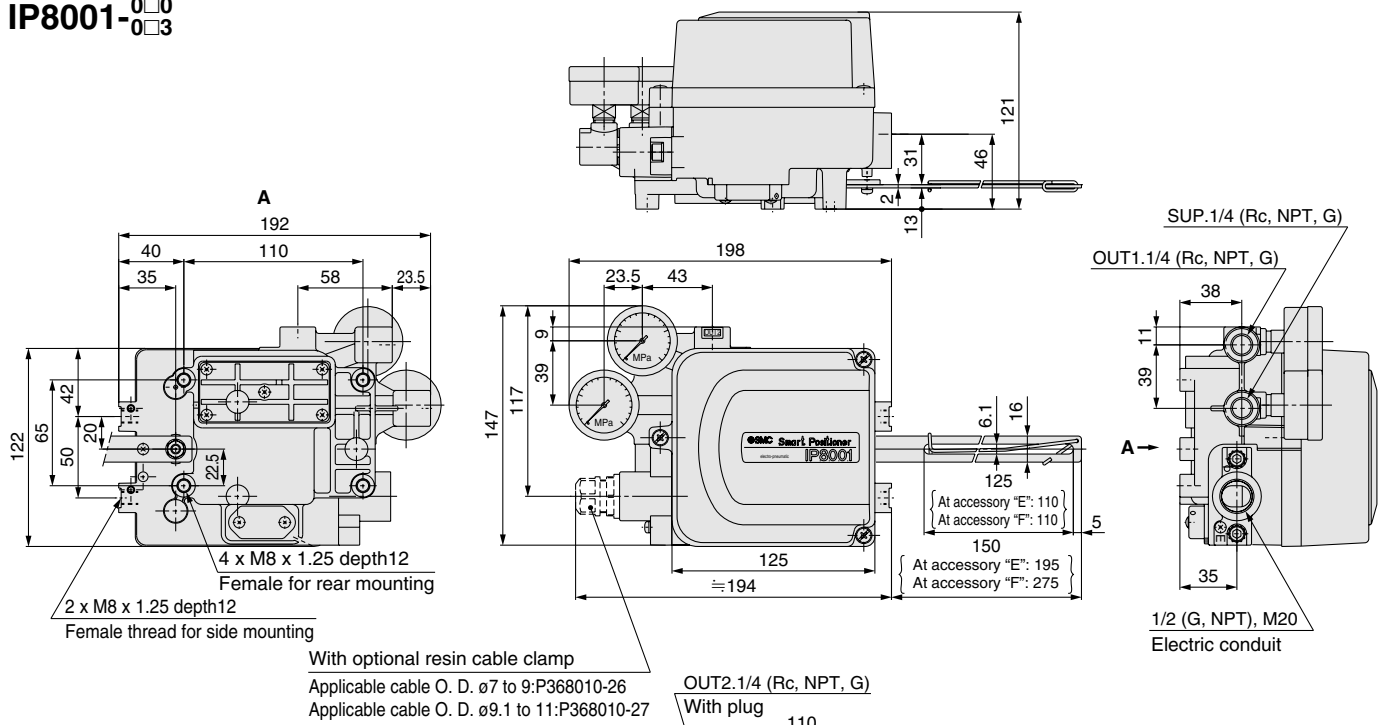

IP8001-**-W**

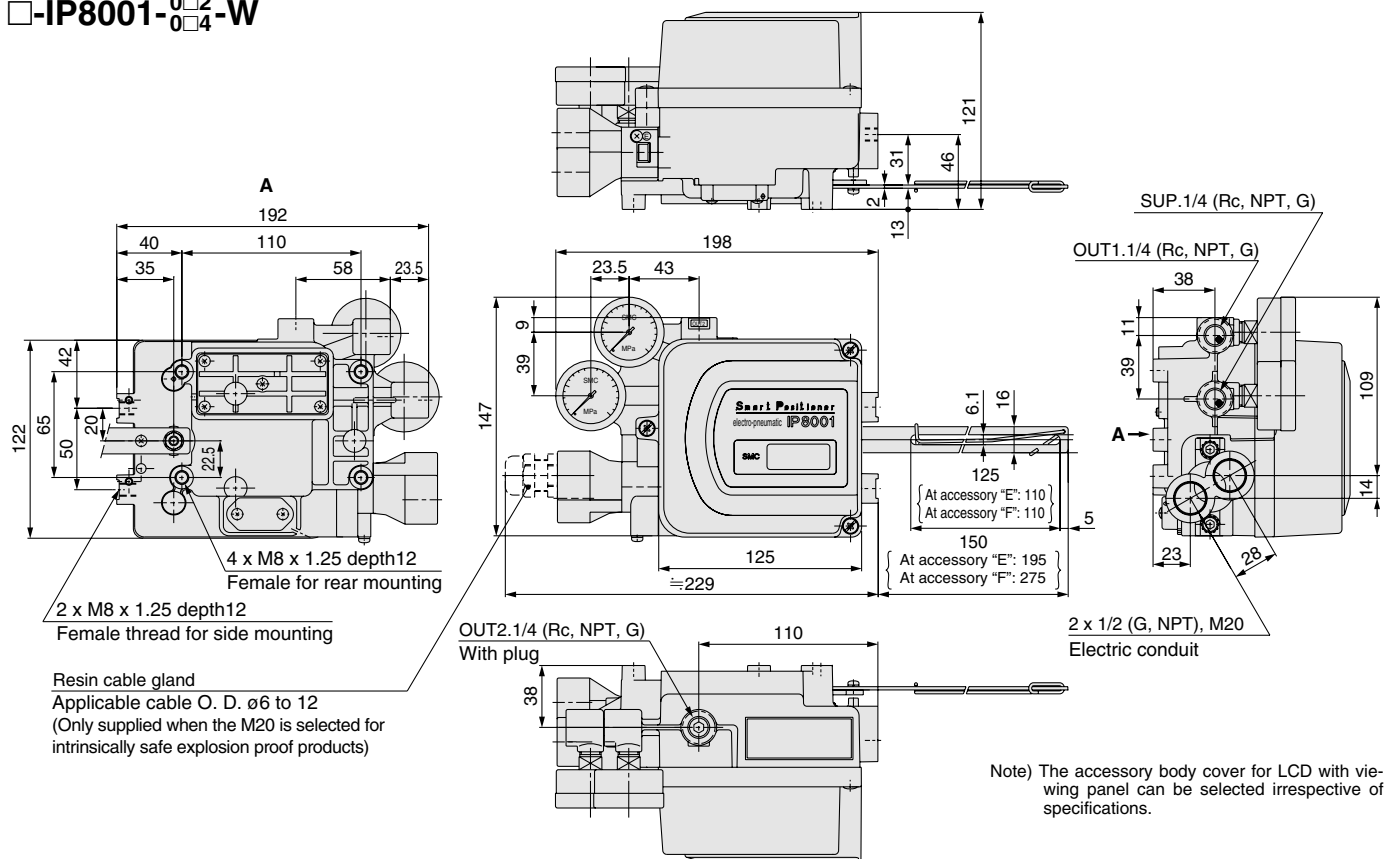

Note) The accessory body cover for LCD with viewing panel can be selected irrespective of specifications.

Series IP8□□

Dimensions / IP8101 (Rotary type)

IP8101- $\begin{matrix} 0\Box 0 \\ 0\Box 3 \end{matrix}$ -W

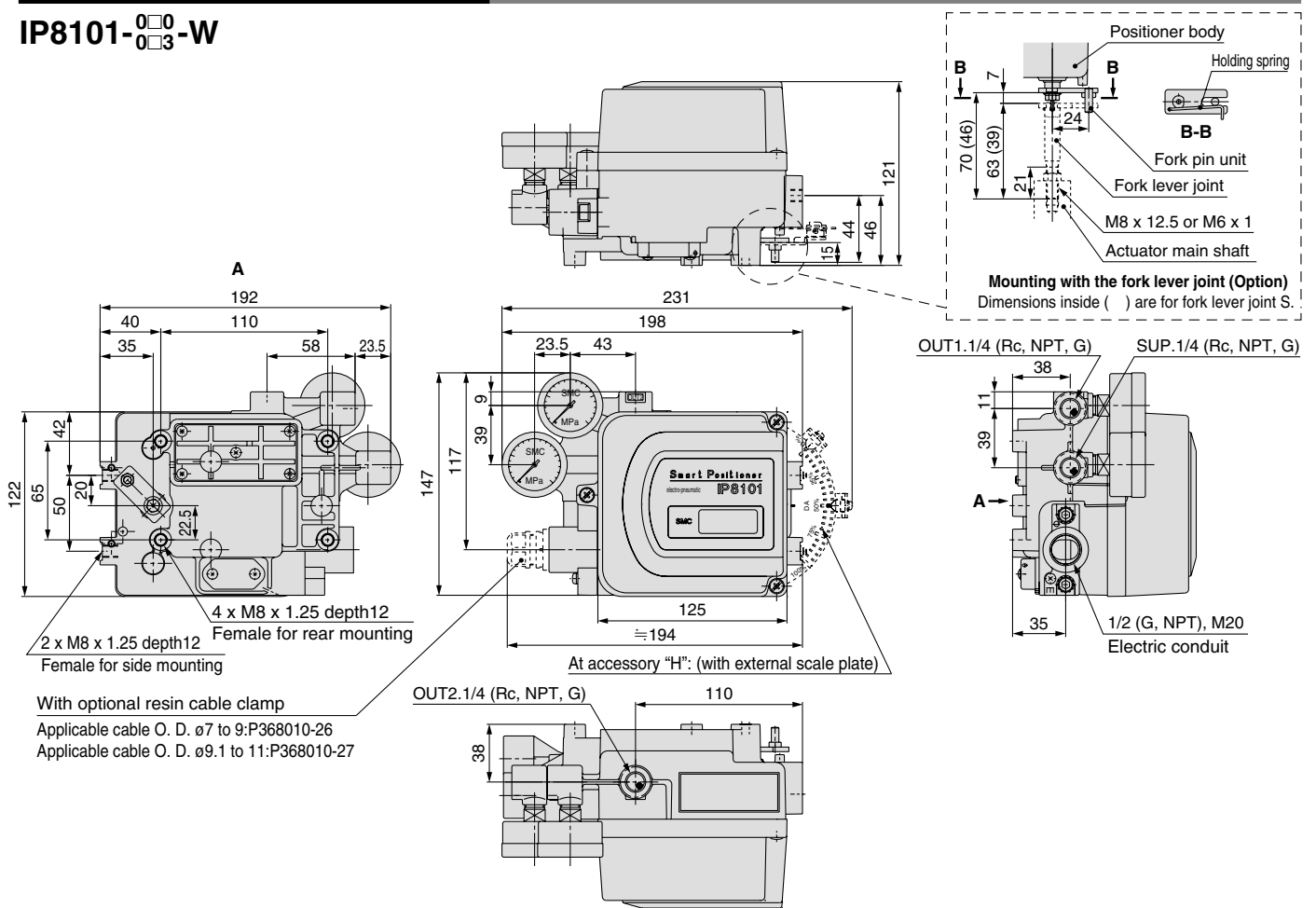

□-IP8101- $\begin{matrix} 0\Box 2 \\ 0\Box 4 \end{matrix}$

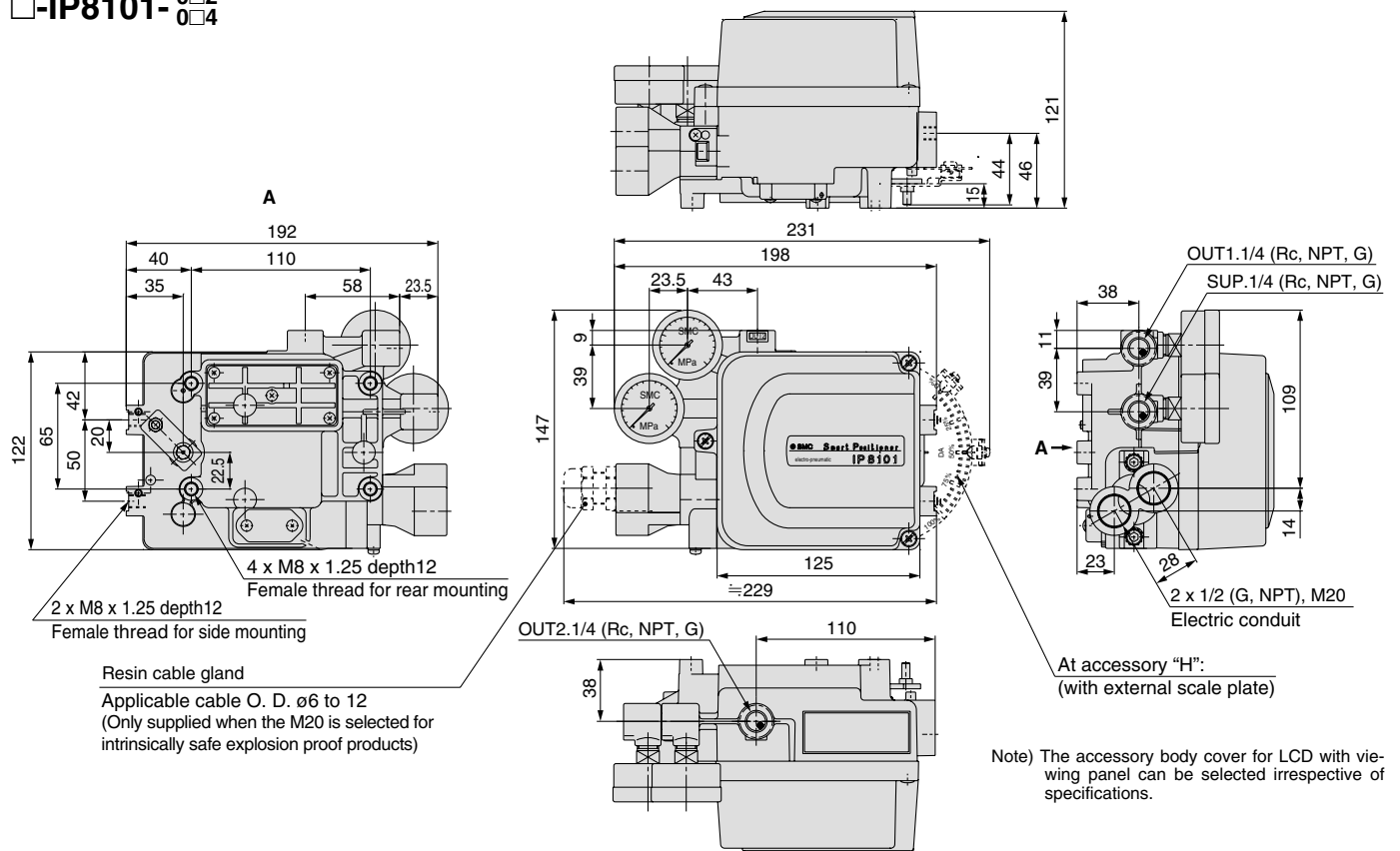

Technical data

Explosion proof

1. TIIS explosion-proof construction

The electro-pneumatic positioner IP8000/8100 becomes explosion proof, as certified by TIIS, according to the model selected. The explosion-proof grade has the following approval: Exd IIBT5.

Take extra care when handling the positioner as explosion-proof equipment

To use as ExdIIBT5

A) Pressure-proof packing.

As shown below in the chart, use "Cable gland" (Option).

B) Metal Piping.

Attach the sealant fitting bracket near the cable port.

(For details, refer to "The guideline on electric equipment explosion proof" published by the Technology Institution of Industrial Safety).

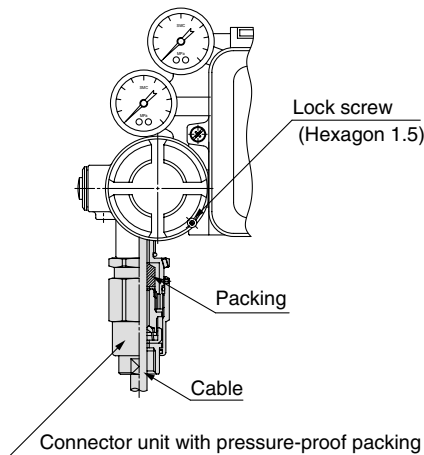

Cable gland with pressure proof packaging (Option)

Description	Unit Product No.	Applicable outside diameter
Connector unit with pressure proof packing	P368010-32	ø7.0 to ø10.0
	P368010-33	ø10.1 to ø12.0

2. ATEX Intrinsically safe explosion-proof construction

Pneumatic positioners IP8000/8100 and IP8001/8101 Smart Positioners are ATEX compliant, intrinsically safe and explosion proof, as certified by KEMA, the accreditation body for explosion-proof products. Take extra care when handling these explosion-proof products.

In regards to explosion-proof grades,

The Pneumatic Positioner IP8□00 meets II2G Ex ib IICT4/T5/T6, and

The Smart Positioner IP8□01 meets the II1G Ex ia IICT4/T5/T6.

Check the positioner's specifications and explosion-proof grades and use in the most optimal environment.

• Wiring

When using the positioner as an intrinsically safe explosion-proof product, always set up a barrier in a **safe environment**, and perform each positioner's wiring through the barrier. Simultaneously, use the provided cable gland (M20 x 1.5) as the extension for the lead wire. If a connecting port other than M20 x 1.5 is selected, the cable gland will not be provided, so use a cable gland with the same or greater explosion-proof grades than this positioner.

• Barrier

Connect the barrier as shown in the diagram below. Moreover, the user must select a barrier that is suitable for each function, based on the ATEX intrinsically safe explosion-proof parameters (current circuit). For IP8001/8101 type smart positioners, use a linear resistant type barrier that is based on the explosion-proof parameters.

Barrier connection diagram

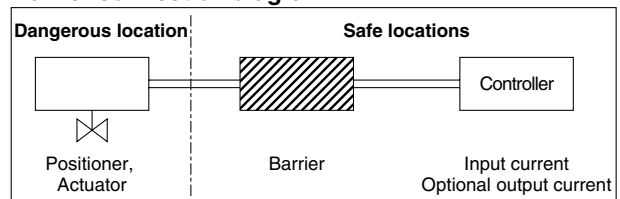

Moreover, at SMC, the barriers listed in the chart below are used to check operations. To purchase, please contact PEPPERL + FUCHS Inc. (Germany).

Recommended barriers

	Manu- facturer	Model	Note	Applicable model	
				IP8□00-X14	52-IP8□01
For input signal (non HART transmission)	PEPPERL + FUCHS (Germany)	KFD2-CD-Ex1.32	—	○	○
For input signal (for HART transmission)		KFD2-SCD-Ex1.LK KCD2-SCD-Ex1	—	—	○
For analogue output		KFD2-STC4-Ex1	—	—	○
For alarm output		KFD2-SOT2-Ex2	Transistor Output passive type	—	○
	KFD2-ST2-Ex2	Transistor Output passive type	—	○	
	KFD2-SR2-Ex2.W	Relay output	—	○	

HART transmission

With smart positioners IP8001/8101, the user can operate the positioner using buttons and change parameter settings by viewing the LCD display (shown the right). Furthermore, depending on the model selected, the same button operation and parameter settings, and monitoring is possible from a remote location via HART transmission.

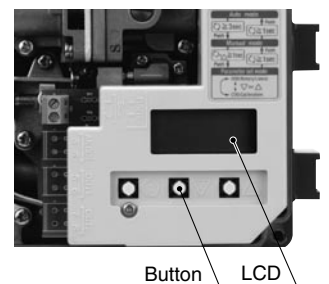

The table below lists an example of applications that are compatible with smart positioner IP8001/8101. Application selection must be made by the user. Please contact Emerson Process Management for further details.

HART transmission compatible application

Product Name ^{Note)}	Manufacturer
AMS™ Suite : Intelligent Device Manager®	Emerson Process Management (US)
375 Field Communicator	



Note) AMS™ Suite: Intelligent Device Manager® is a registered trademark of Emerson Electric Co.



Safety Instructions

These safety instructions are intended to prevent hazardous situations and/or equipment damage. These instructions indicate the level of potential hazard with the labels of “**Caution,**” “**Warning**” or “**Danger.**” They are all important notes for safety and must be followed in addition to International Standards (ISO/IEC)^{Note 1)}, and other safety regulations.

Note 1) ISO 4414: Pneumatic fluid power – General rules relating to systems.
ISO 4413: Hydraulic fluid power – General rules relating to systems.
IEC 60204-1: Safety of machinery – Electrical equipment of machines. (Part 1: General requirements)
ISO 10218-1: Manipulating industrial robots - Safety.
etc.

-  **Caution:** **Caution** indicates a hazard with a low level of risk which, if not avoided, could result in minor or moderate injury.
-  **Warning:** **Warning** indicates a hazard with a medium level of risk which, if not avoided, could result in death or serious injury.
-  **Danger :** **Danger** indicates a hazard with a high level of risk which, if not avoided, will result in death or serious injury.

Warning

1. The compatibility of the product is the responsibility of the person who designs the equipment or decides its specifications.

Since the product specified here is used under various operating conditions, its compatibility with specific equipment must be decided by the person who designs the equipment or decides its specifications based on necessary analysis and test results. The expected performance and safety assurance of the equipment will be the responsibility of the person who has determined its compatibility with the product. This person should also continuously review all specifications of the product referring to its latest catalogue information, with a view to giving due consideration to any possibility of equipment failure when configuring the equipment.

2. Only personnel with appropriate training should operate machinery and equipment.

The product specified here may become unsafe if handled incorrectly. The assembly, operation and maintenance of machines or equipment including our products must be performed by an operator who is appropriately trained and experienced.

3. Do not service or attempt to remove product and machinery/equipment until safety is confirmed.

1. The inspection and maintenance of machinery/equipment should only be performed after measures to prevent falling or runaway of the driven objects have been confirmed.
2. When the product is to be removed, confirm that the safety measures as mentioned above are implemented and the power from any appropriate source is cut, and read and understand the specific product precautions of all relevant products carefully.
3. Before machinery/equipment is restarted, take measures to prevent unexpected operation and malfunction.

4. Contact SMC beforehand and take special consideration of safety measures if the product is to be used in any of the following conditions.

1. Conditions and environments outside of the given specifications, or use outdoors or in a place exposed to direct sunlight.
2. Installation on equipment in conjunction with atomic energy, railways, air navigation, space, shipping, vehicles, military, medical treatment, combustion and recreation, or equipment in contact with food and beverages, emergency stop circuits, clutch and brake circuits in press applications, safety equipment or other applications unsuitable for the standard specifications described in the product catalogue.
3. An application which could have negative effects on people, property, or animals requiring special safety analysis.
4. Use in an interlock circuit, which requires the provision of double interlock for possible failure by using a mechanical protective function, and periodical checks to confirm proper operation.



Safety Instructions

Caution

1. The product is provided for use in manufacturing industries.

The product herein described is basically provided for peaceful use in manufacturing industries.

If considering using the product in other industries, consult SMC beforehand and exchange specifications or a contract if necessary.

If anything is unclear, contact your nearest sales branch.

Limited warranty and Disclaimer/Compliance Requirements

The product used is subject to the following “Limited warranty and Disclaimer” and “Compliance Requirements”. Read and accept them before using the product.

Limited warranty and Disclaimer

1. The warranty period of the product is 1 year in service or 1.5 years after the product is delivered.^{Note 2)}
Also, the product may have specified durability, running distance or replacement parts. Please consult your nearest sales branch.
2. For any failure or damage reported within the warranty period which is clearly our responsibility, a replacement product or necessary parts will be provided.
This limited warranty applies only to our product independently, and not to any other damage incurred due to the failure of the product.
3. Prior to using SMC products, please read and understand the warranty terms and disclaimers noted in the specified catalogue for the particular products.

Note 2) Vacuum pads are excluded from this 1 year warranty.

A vacuum pad is a consumable part, so it is warranted for a year after it is delivered.

Also, even within the warranty period, the wear of a product due to the use of the vacuum pad or failure due to the deterioration of rubber material are not covered by the limited warranty.

Compliance Requirements

1. The use of SMC products with production equipment for the manufacture of weapons of mass destruction (WMD) or any other weapon is strictly prohibited.
2. The exports of SMC products or technology from one country to another are governed by the relevant security laws and regulations of the countries involved in the transaction. Prior to the shipment of a SMC product to another country, assure that all local rules governing that export are known and followed.



Series IP8□

Electro-Pneumatic Positioner/Smart Positioner Precautions 1

Be sure to read before handling.

Operation

⚠ Warning

1. Do not operate the positioner outside the specified range as this may cause problems. (Refer to the specifications.)
2. Design the system to include a safety circuit to avoid the risk of danger should the positioner suffer failure.
3. Be sure that exterior lead-in wiring to the terminal box is based on the guidelines for explosion-protection of manufactory electric equipment when being used as a flame proof, explosion proof construction.
4. Do not remove terminal cover in a hazardous location while the power is on.
5. Covers for the terminal and body should be in place while operating.
6. When using as an intrinsically safe explosion-proof product, do not wire in a hazardous location while the power is on.

⚠ Caution

1. Do not touch the actuator or valve's oscillating section when supply pressure has been added, as this is dangerous.
2. Make sure fingers do not get caught when mounting and aligning the cam.
Cut off the pressure supply and always release the compressed air inside the positioner and actuator before performing this work.
3. Always use with the body cover unit mounted.
Moreover, the positioner may not meet degrees of protection IP65 depending on the body cover mounting conditions. In order to meet degrees of protection IP65, tighten threads using the proper tightening torques (2.8 to 3.0 N·m).
4. Always flush the pipe's inside before piping to ensure foreign objects such as machining chips do not enter the positioner.
5. The actuator opening may become unstable when using the booster relay.
6. Always use a ground connection to prevent noise from the input current and to prevent damage because of static electricity.
7. Use the pressure reading on the supplied pressure gauge as an indication.
8. The supplied pressure gauge's needle will malfunction if the pressure supply to the internal mechanism or positioner freezes.

Ensure that the pressure gauge's internal parts do not freeze if using the pressure gauge in an operating environment with an ambient temperature of less than 0°C.

For users

⚠ Caution

1. Assemble, operate and maintain the positioners after reading the operation manual thoroughly and understanding the content.

Handling

⚠ Caution

1. Avoid excessive vibration or impact to the positioner body and any excessive force to the armature, as these actions may cause damage to the product. Handle carefully while transporting and operating.
2. If being used in a place where vibration occurs, using a binding band is recommended to prevent broken wires because of the vibration.
3. When exposed to possible moisture invasion, please take the necessary measures. For example, if the positioner is left on-site for long periods, a plug should be put in the piping port and a body cover unit fitted to avoid water penetration.
Take measures to avoid dew condensation inside the positioner if exposed to high temperature and humidity. Take enough measures against condensation especially when packing for export.
4. Keep magnetic field off the positioner, as this affects its characteristics.

Air Supply

⚠ Caution

1. Use only dehumidified and dust extracted clean compressed air as the air supply.
2. Use only dehumidified and dust-extracted clean compressed clean air as the positioner contains extra-fine orifices such as restrictor and nozzle.
Do not use a lubricator.
3. Do not use compressed air containing chemicals, organic solvents, salinity or corrosive gases, as this may cause malfunction.
4. When operating below the freezing point, protect the positioner from freezing.



Series IP8□

Electro-Pneumatic Positioner/Smart Positioner Precautions 2

Be sure to read before handling.

Operating Environment

⚠ Caution

1. Do not operate in locations with an atmosphere of corrosive gases, chemicals, sea water, or where these substances will adhere to the regulator.
2. Do not operate out of the indicated operation temperature range as this may cause damage to electronic parts and seal materials to deteriorate.
3. Do not operate in locations where excessive vibration or impact occurs.
4. If the body cover is being installed in a place where the body cover is exposed to direct sunlight, the use of a standard body cover without the LCD window is recommended.

Maintenance

⚠ Warning

1. **After installation, repair or disassembly, connect compressed air and conduct tests to confirm appropriate function and leakage.**
Do not use the positioner when noise from the bleeder sounds louder compared with the initial state, or when it does not operate normally. If these occur, check immediately if assembled and mounted correctly.
Never modify electrical construction to maintain explosion-proof construction.

⚠ Caution

1. **Confirm whether the compressed air is clean.**
Dust, oil, or moisture mixed within the equipment may result in malfunction and positioner problems. Perform periodic inspection of the air preparation equipment to ensure clean air is always supplied.
2. **Improper handling of compressed air is dangerous. Not only observing the product specifications, but also replacement of elements and other maintenance activities should be conducted by personnel having sufficient knowledge and experience pertaining to instrumentation equipment.**
3. **Perform annual inspections of the positioner.**
Replace badly damaged seals and units such as diaphragm and O-ring during the inspection.
When used in tough environmental and/or service conditions such as seaside locations, replacements should be undertaken more frequently.

Maintenance

⚠ Caution

4. When performing inspections, demounting the positioner, or replacing the elements with the positioner still in its mounted position, first, stop the compressed air, then exhaust the residual pressure before undertaking operation.
5. Should the restrictor become clogged with carbon particles, etc., demount automatic/manual change-over screw (with built-in restrictor) and clean it using a $\varnothing 0.2$ wire.
Stop the compressed air and remove the screw to switch the pilot valve off before replacing the restrictor.
6. **Apply just a small amount of silicone grease set by SMC to the sliding parts (O-ring and exhaust valve) when disassembling a pilot valve unit.**
Replacing the valve unit every three years is recommended.
7. **Check air leakage from pipes that pass compressed air and connecting parts.**
Air leakage from air piping results in reduced operational performance and a decline of characteristics, etc.
It is structurally necessary for air to be released from the bleeder, it is not abnormal as long as the air consumption is within the specified range.

EUROPEAN SUBSIDIARIES:

Austria

SMC Pneumatik GmbH (Austria).
Girakstrasse 8, A-2100 Korneuburg
Phone: +43 2262-622800, Fax: +43 2262-62285
E-mail: office@smc.at
http://www.smc.at

France

SMC Pneumatique, S.A.
1, Boulevard de Strasbourg, Parc Gustave Eiffel
Bussy Saint Georges F-77607 Marne La Vallée Cedex 3
Phone: +33 (0)1-6476 1000, Fax: +33 (0)1-6476 1010
E-mail: contact@smc-france.fr
http://www.smc-france.fr

Netherlands

SMC Pneumatics BV
De Ruyterkade 120, NL-1011 AB Amsterdam
Phone: +31 (0)20-5318888, Fax: +31 (0)20-5318880
E-mail: info@smcpneumatics.nl
http://www.smcneumatics.nl

Spain

SMC España, S.A.
Zuazobidea 14, 01015 Vitoria
Phone: +34 945-184 100, Fax: +34 945-184 124
E-mail: post@smc.smces.es
http://www.smc.eu

Belgium

SMC Pneumatics N.V./S.A.
Nijverheidsstraat 20, B-2160 Wommelgem
Phone: +32 (0)3-355-1464, Fax: +32 (0)3-355-1466
E-mail: info@smcpneumatics.be
http://www.smcneumatics.be

Germany

SMC Pneumatik GmbH
Boschring 13-15, D-63329 Egelsbach
Phone: +49 (0)6103-4020, Fax: +49 (0)6103-402139
E-mail: info@smc-pneumatik.de
http://www.smc-pneumatik.de

Norway

SMC Pneumatics Norway A/S
Vollsveien 13 C, Granfos Næringspark N-1366 Lysaker
Tel: +47 67 12 90 20, Fax: +47 67 12 90 21
E-mail: post@smc-norge.no
http://www.smc-norge.no

Sweden

SMC Pneumatics Sweden AB
Ekhagsvägen 29-31, S-141 71 Huddinge
Phone: +46 (0)8-603 12 00, Fax: +46 (0)8-603 12 90
E-mail: post@smcpneumatics.se
http://www.smc.nu

Bulgaria

SMC Industrial Automation Bulgaria EOOD
Business Park Sofia, Building 8 - 6th floor, BG-1715 Sofia
Phone: +359 2 9744492, Fax: +359 2 9744519
E-mail: office@smc.bg
http://www.smc.bg

Greece

SMC Hellas EPE
Anagenniseos 7-9 - P.C. 14342, N. Philadelphia, Athens
Phone: +30-210-2717265, Fax: +30-210-2717766
E-mail: sales@smchellas.gr
http://www.smchellas.gr

Poland

SMC Industrial Automation Polska Sp.z.o.o.
ul. Poloneza 89, PL-02-826 Warszawa
Phone: +48 22 211 9600, Fax: +48 22 211 9617
E-mail: office@smc.pl
http://www.smc.pl

Switzerland

SMC Pneumatik AG
Dorfstrasse 7, CH-8484 Weisslingen
Phone: +41 (0)52-396-3131, Fax: +41 (0)52-396-3191
E-mail: info@smc.ch
http://www.smc.ch

Croatia

SMC Industrijska automatika d.o.o.
Crnomerec 12, HR-10000 ZAGREB
Phone: +385 1 377 66 74, Fax: +385 1 377 66 74
E-mail: office@smc.hr
http://www.smc.hr

Hungary

SMC Hungary Ipari Automatizálási Kft.
Torbágy út 19, H-2045 Törökbalint
Phone: +36 23 511 390, Fax: +36 23 511 391
E-mail: office@smc.hu
http://www.smc.hu

Portugal

SMC Sucursal Portugal, S.A.
Rua de Eng^o Ferreira Dias 452, 4100-246 Porto
Phone: +351 226 166 570, Fax: +351 226 166 589
E-mail: postpt@smc.smces.es
http://www.smc.eu

Turkey

Entek Pnömatik San. ve Tic. A*.
Perpa Ticaret Merkezi B Blok Kat:11 No: 1625, TR-34386, Okmeydanı, Istanbul
Phone: +90 (0)212-444-0762, Fax: +90 (0)212-221-1519
E-mail: smc@entek.com.tr
http://www.entek.com.tr

Czech Republic

SMC Industrial Automation CZ s.r.o.
Hudcova 78a, CZ-61200 Brno
Phone: +420 5 414 24611, Fax: +420 5 412 18034
E-mail: office@smc.cz
http://www.smc.cz

Ireland

SMC Pneumatics (Ireland) Ltd.
2002 Citywest Business Campus, Naas Road, Saggart, Co. Dublin
Phone: +353 (0)1-403 9000, Fax: +353 (0)1-464-0500
E-mail: sales@smcpneumatics.ie
http://www.smcneumatics.ie

Romania

SMC Romania srl
Str Frunzei 29, Sector 2, Bucharest
Phone: +40 213205111, Fax: +40 213261489
E-mail: smcromania@smcromania.ro
http://www.smcromania.ro

UK

SMC Pneumatics (UK) Ltd
Vincent Avenue, Crownhill, Milton Keynes, MK8 0AN
Phone: +44 (0)845 121 5122 Fax: +44 (0)1908-555064
E-mail: sales@smcpneumatics.co.uk
http://www.smcneumatics.co.uk

Denmark

SMC Pneumatik A/S
Egeskovvej 1, DK-8700 Horsens
Phone: +45 70252900, Fax: +45 70252901
E-mail: smc@smcdk.com
http://www.smcdk.com

Italy

SMC Italia S.p.A
Via Garibaldi 62, I-20061 Carugate, (Milano)
Phone: +39 (0)2-92711, Fax: +39 (0)2-9271365
E-mail: mailbox@smcitalia.it
http://www.smcitalia.it

Russia

SMC Pneumatik LLC.
4B Sverdlovskaja nab, St. Petersburg 195009
Phone: +7 812 718 5445, Fax: +7 812 718 5449
E-mail: info@smc-pneumatik.ru
http://www.smc-pneumatik.ru

Estonia

SMC Pneumatics Estonia OÜ
Laki 12, 106 21 Tallinn
Phone: +372 6510370, Fax: +372 65110371
E-mail: smc@smcpneumatics.ee
http://www.smcneumatics.ee

Latvia

SMC Pneumatics Latvia SIA
Dzelzavas str. 120g, Riga LV-1021, LATVIA
Phone: +371 67817700, Fax: +371 67817701
E-mail: info@smclv.lv
http://www.smclv.lv

Slovakia

SMC Priemyselna Automatizacia, s.r.o.
Fatranska 1223, 01301 Teplicka Nad Vahom
Phone: +421 41 3213212 - 6 Fax: +421 41 3213210
E-mail: office@smc.sk
http://www.smc.sk

Finland

SMC Pneumatics Finland Oy
PL72, Tiistinniityntie 4, SF-02231 ESPOO
Phone: +358 207 513513, Fax: +358 207 513599
E-mail: smcfin@smc.fi
http://www.smc.fi

Lithuania

SMC Pneumatics Lietuva, UAB
Oslo g.1, LT-04123 Vilnius
Phone: +370 5 2308118, Fax: +370 5 2648126
E-mail: info@smclt.lt
http://www.smclt.lt

Slovenia

SMC industrijska Avtomatika d.o.o.
Mirska cesta 7, SI-8210 Trebnje
Phone: +386 7 3885412 Fax: +386 7 3885435
E-mail: office@smc.si
http://www.smc.si

OTHER SUBSIDIARIES WORLDWIDE:

ARGENTINA, AUSTRALIA, BOLIVIA, BRASIL, CANADA, CHILE,
CHINA, HONG KONG, INDIA, INDONESIA, MALAYSIA, MEXICO,
NEW ZEALAND, PHILIPPINES, SINGAPORE, SOUTH KOREA,
TAIWAN, THAILAND, USA, VENEZUELA

<http://www.smc.eu>
<http://www.smcworld.com>