



ISO 9001

SERIES 10 & 20

ECONOMICAL
ONE-PIECE / TWO-PIECE BALL VALVES
STAINLESS STEEL AND CARBON STEEL
THREADED ENDS 1000/1500/2000 PSI

FEATURES

- For General Industrial and Chemical Applications, provides Safe, Economical Performance
- Economical Compact Design
- Blow-Out Proof Stem
- Low Operation Torque
- Investment Cast Body Construction

FIG. 10-10 REDUCED PORT 1/4" TO 2" 1000 PSI



MATERIALS LIST			
NO.	PART NAME	MATERIAL	QTY
1	Body	ASTM A361 Gr. CPM	1
2	Cap	ASTM A361 Gr. CPM	1
3	Ball	SUS 316	1
4	Stem	SUS 316	1
5	Stem Nut	SUS 304	1
6	Stem Washer	SUS 304	1
7	Handle	SUS 304	1
8	Seat	PTFE	2
9	Gland	SUS 304	1
10	Stem Packing	PTFE	1
11	Thrust Washer	PTFE	1
12	Handle Sleeve	Vinyl	1
13	Joint Gasket	PTFE	1
14	Locking Device	SUS 304	1

Available as an option

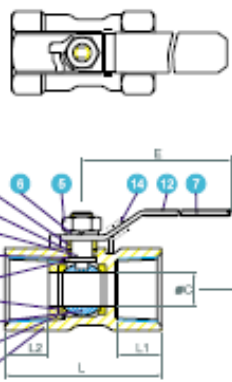

Pressure Vs. Temperature Chart

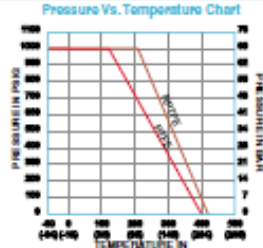

DIMENSIONS(mm)						
SIZE	ØC	E	H	L	L2	W(Kg)
1/4"	5.0	64	35	39	11.0	0.07
3/8"	7.0	70	37	44	11.0	0.10
1/2"	9.2	90	44	57	15.0	0.16
3/4"	12.5	90	47	59	15.0	0.25
1"	15.0	103	50	71	17.4	0.43
1 1/4"	20.0	103	57	78	19.0	0.70
1 1/2"	25.0	127	69	83	19.1	0.83
2"	32.0	127	75	100	22.5	1.50

FIG. 20-10 FULL PORT 1/4" TO 2" 1000 PSI



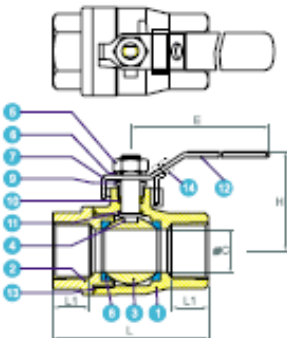

DIMENSIONS(mm)

SIZE	ØC	E	H	L1	L	W(Kg)
1/4"	11.2	100	50	12	56	0.23
3/8"	12.6	100	50	13	56	0.23
1/2"	15.0	130	60	14	66	0.36
3/4"	20.0	130	64	16	72	0.47
1"	25.0	165	71	18	84	0.82
1 1/4"	32.0	165	78	20	94	1.17
1 1/2"	38.0	190	86	22	110	1.82
2"	50.0	190	95	25	126	2.83

FIG. 20-20 FULL PORT 1/4" TO 3" 1000 PSI



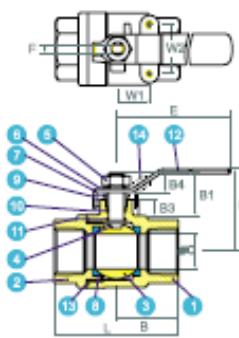

DIMENSIONS(mm)

SIZE	B	B1	B3	B4	ØC	E	F	H	L	L1	W1	W2	W3	W4	W(kg)
1/4"	27.5	23	8	10	11.8	100	5.0	50	55	12.7	28.5	N/A	N/A	N/A	0.23
3/8"	27.5	23	8	10	12.7	100	5.0	50	55	12.7	28.5	N/A	N/A	N/A	0.23
1/2"	32.5	26	10	12	15.0	130	6.5	60	65	12.7	28.5	N/A	N/A	N/A	0.36
3/4"	37.0	26	11	12	20.0	130	6.5	64	74	22.4	35.0	N/A	N/A	N/A	0.52
1"	44.0	30	12	15	25.0	165	8.0	71	88	22.4	35.0	N/A	N/A	N/A	0.92
1 1/4"	51.0	37	12	15	32.0	165	8.0	78	102	25.4	38.1	N/A	N/A	N/A	1.32
1 1/2"	55.0	35	12	15	38.0	190	9.7	85	110	25.4	38.1	N/A	N/A	N/A	1.90
2"	62.5	31	10	15	50.0	190	9.7	95	125	25.4	38.1	N/A	N/A	N/A	3.12
2 1/2"	61.5	51	18	25	65.0	250	12.0	130	182	N/A	N/A	59	61	6.50	
3"	69.0	49	18	25	80.0	250	12.0	145	178	N/A	N/A	70	71	9.30	

Top Mounting Location for 2 1/2" - 3"
Side Mounting Location for 2 1/2" - 3"



FIG. 20-30 REDUCED PORT 1/4" TO 1" 2000 PSI 1 1/4" TO 2" 1500 PSI

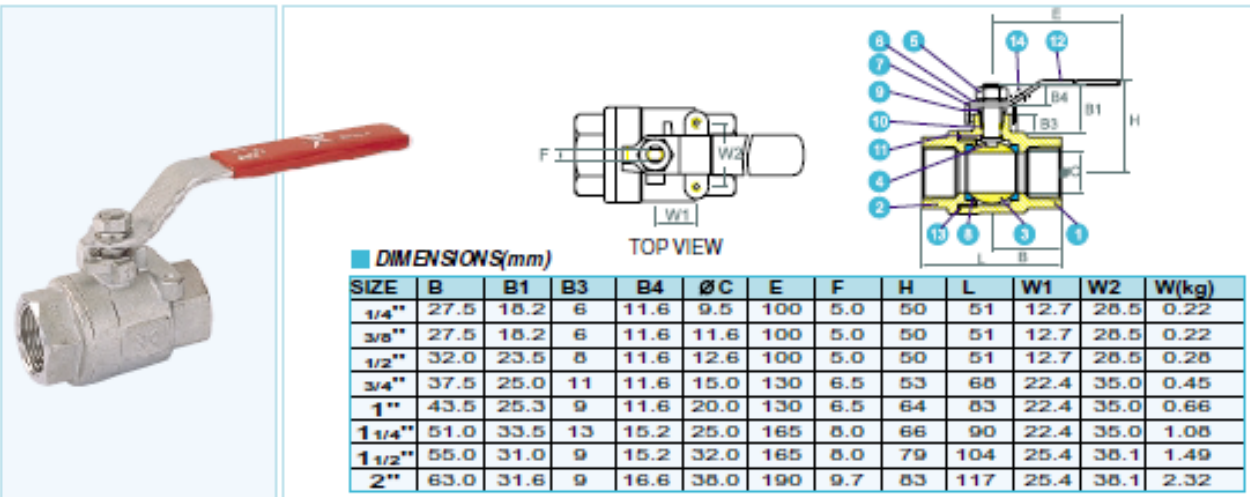

FIG. 20-40 FULL PORT 1/4" TO 1" 2000 PSI 1 1/4" TO 2" 1500 PSI

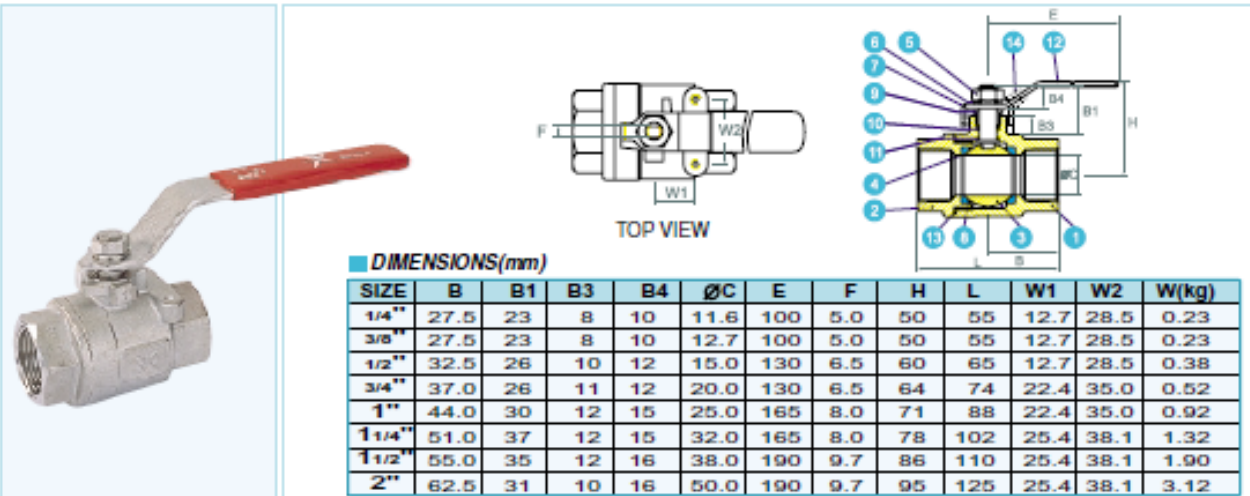

FIG. 20-50 FULL PORT 1/2" TO 3" 1000 PSI

