

### Main Features :-

AVA Basic and Smart Actuated Valves

IP67 ABS or Aluminium Housing

Manual Override and internal heater

On Off, Failsafe, Modulating, Bus and Hi Speed

Stainless 2pc Flanged PN16 or ANSI 150

Valve has RPTFE seats and Viton seals.

1" to 4" from Stock



TYPE: ACTUATED VALVES

### Actuated Valve Overview:-

AVA Electric actuators offer a compact actuated valve solution with almost all valves they are assembled to. AVA basic actuators offer entry level actuator series with a 'Basic' on off and failsafe functionality. Our Smart series offers the addition of an OLED screen with actuator status display, input command display and menu system to customise the actuator functions. This includes changing the working time, working angle and accuracy. AVA smart actuators are available as on off, failsafe, modulating, modulating failsafe, BUS communication, hi speed and wireless.

The valve used in this assembly will typically be our Genebre flanged series 2528. Full bore, stainless steel 2pc flanged PN16 ball valve, RPTFE seats and Viton seals with option of ANSI 150 flanged ends or PN40 flanged ends. 2528 PN16 valve is ATEX approved. (AVA actuators not currently ATEX approved)

Available with a high / low temperature kit for applications where needed. See dimensions below, typically a kit will add 50mm on smaller sizes and 70mm on larger sizes.

### Key Dimensions:-

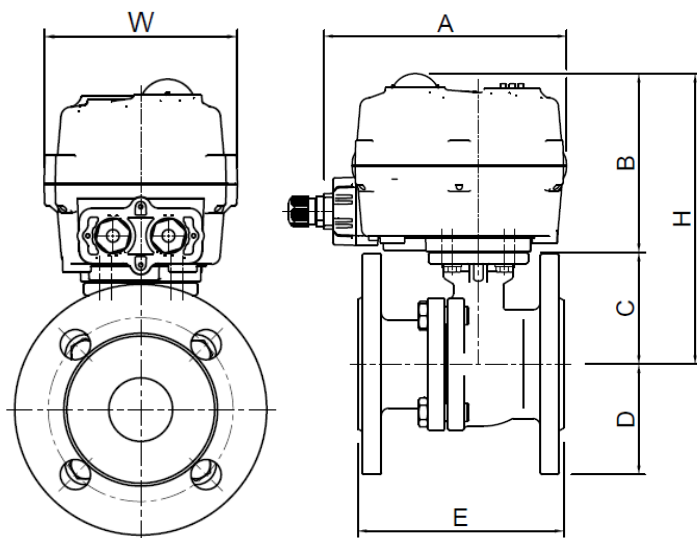

AVA Actuated Valves - Sizes are in mm					
Size	A	W	E	B	Kit
1/2"	102	70	115	83.3	50
3/4"	102	70	120	83.3	50
1"	102	70	125	83.3	50
1 1/4"	102	70	130	83.3	50
1 1/2"	165	115	140	122	50
2"	165	115	150	122	50
2 1/2"	165	115	170	122	50
3"	165	115	180	122	70
4"	165	115	190	122	70

ISO 9001:2015 Accredited Company

Tel: +44(0)1386 552369

Fax: +44(0)1386 554227

sales@allvalves.co.uk

www.allvalves.co.uk

Allvalves Online Ltd, Automation House, Unit 2, Pershore, WR10 2DF UK

### Wiring and Additional Technical Specifications:-

TYPE: ACTUATED VALVES

#### Wiring Diagrams :-

##### Basic & Smart On Off - Failsafe

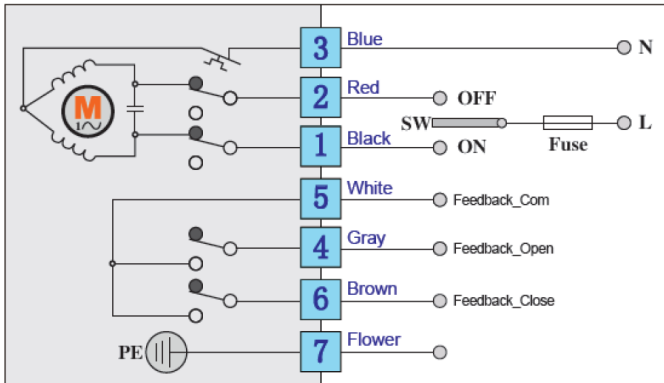

Volt free aux contacts

AVA actuators offer a 3 wire system with a permanent neutral on Blue, switchable Live between pins 2 (Red) and 1 (Black). Actuators are supplied with the a Pin connector as shown below as standard on model 20's. On model 60/110 the actuator has a terminal strip as standard.

##### Smart Modulating Actuators

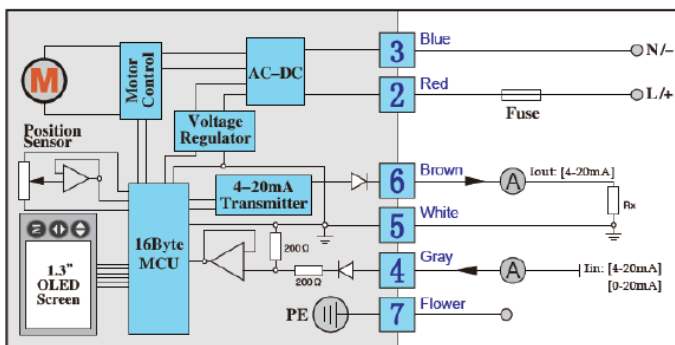

AVA Modulating actuators are wired as shown on the left, image shows 4-20ma, check actuator datasheet for other wiring options. Actuators are supplied with the a Pin connector as shown below as standard on model 20's. On model 60/110 the actuator has a terminal strip as standard.

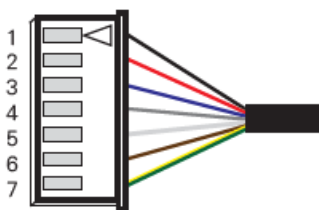

AVA actuators come with the white pin connector shown on the left, this is mainly for our benefit as this allows fast testing when used with our test boxes. This connector can either be utilised or cut to leave bare cable which need terminating. Note that this does NOT invalidate your warranty on the actuator.

**IMPORTANT** - For Failsafe electric actuators, our 20 Series actuators use an internal capacitor to achieve the failsafe functionality. This means that when you first power the actuators, they will require an initial charge. This is not the same as the 60 /110 series that use a battery for failsafe. The capacitor only needs a 15-30 second initial charge or when first using after a period of time without using. The battery actuators are charged whilst powered and are supplied with charged batteries.

### Wiring and Additional Technical Specifications:-

#### Valve Details :-

#### Características

1. Válvula de esfera paso total, 2 piezas.
2. Extremos Bridados según EN 1092.  
PN 40 desde DN 15 hasta DN 50.  
PN 16 desde DN 65 hasta DN 200.
3. Construcción en Acero Inoxidable 1.4408 (CF8M).
4. Longitud entre caras según EN 558 serie 27.
5. Asientos PTFE + 15 % F.V.  
(otro material consultar)
6. Junta cuerpo espirometálica desde DN 32.
7. Tórica en el eje de FKM (Viton).
8. Vástago inextinguible.
9. Montaje actuador directo según ISO 5211.
10. Sistema de bloqueo incorporado.
11. Dispositivo Anti-estático.
12. Diseño anti-fuego.
13. Presión de trabajo máxima 40 / 16 bar.
14. Temperatura de trabajo -30 °C + 180 °C.

#### Features

1. Full port ball valve, 2 pieces.
2. Flanged ends according to EN 1092.  
PN 40 DN 15 to DN 50.  
PN 16 DN 65 to DN 200.
3. Made of Stainless Steel 1.4408 (CF8M).
4. Face to Face according to EN 558 series 27.
5. Ball seats PTFE + 15 % G.F.  
(please ask for other materials)
6. From DN 32 with spiral wound gasket..
7. FKM (Viton) stem O' ring.
8. Blow-out proof stem.
9. Direct mounting actuator according to ISO 5211.
10. Block System included.
11. Anti-static device.
12. Fire-safe design.
13. Max. Working pressure 40 / 16 bar.
14. Working Temperature -30 °C + 180 °C.

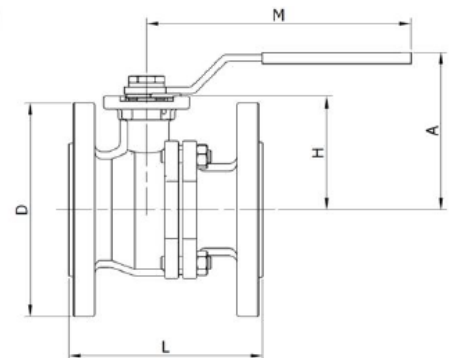
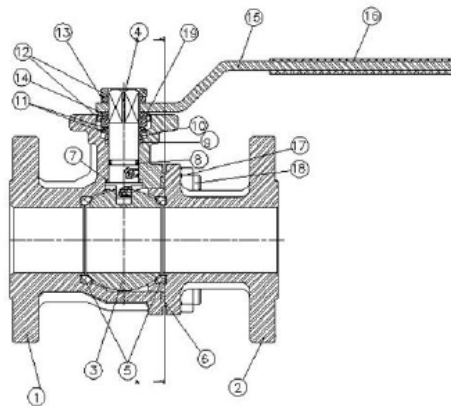

Ref.	Medida/ Size	PN	Dimensiones/Dimensions (mm)								Peso/ Weight (Kg)
			D	A	L	M	C x C	ISO 5211	H	h	
2528 04	1/2"	40	95	85	115	170	9 x 9	F04	46	9,5	2,200
2528 05	3/4"	40	105	85	120	170	9 x 9	F04/F05	51	10	3,050
2528 06	1"	40	116	95	125	170	11 x 11	F04/F05	57	11	3,750
2528 07	1 1/4"	40	140	106	130	200	14 x 14	F05/F07	71	15,5	5,750
2528 08	1 1/2"	40	150	110	140	200	14 x 14	F05/F07	76	15,5	7,000
2528 09	2"	40	165	118	150	200	14 x 14	F05/F07	83	15,5	9,500
2528 10	2 1/2"	16	185	170	170	380	17 x 17	F07/F10	119	21	14,750
2528 11	3"	16	200	170	180	380	17 x 17	F07/F10	130	21	18,850
2528 12	4"	16	220	170	190	380	17 x 17	F07/F10	145	21	26,250
2528 13	5"	16	250	200	325	520	27 x 27	F10/F12	163	34	38,000
2528 14	6"	16	285	220	350	620	27 x 27	F10/F12	180	34	51,000
2528 16	8"	16	340	300	400	700	25 x 25	F12	-	-	106,700

ISO 9001:2015 Accredited Company

Tel: +44(0)1386 552369

Fax: +44(0)1386 554227

sales@allvalves.co.uk

www.allvalves.co.uk

Allvalves Online Ltd, Automation House, Unit 2, Pershore, WR10 2DF UK

### Wiring and Additional Technical Specifications:-

Actuator Details :- Typical actuator details for on off actuator.

Model:	AVA-B20 20Nm BASIC ON-OFF ELECTRIC ACTUATOR				
	AC 1ph 50/60Hz			DC	
Rated Voltage	AC230V	AC110V	AC24V	DC24V	DC12V
Voltage Range	AC 190-250V	AC90-130V	AC22-28V	DC22-28V	DC10-15V
Consumption	13.2W run, 0W hold	15W run, 0W hold	10.8W run, 0W hold	9.6W run, 0.3W hold	93.5W run, 0.3W hold
Peak current	60mA for 5ms	135mA for 5ms	450mA for 5ms	500mA for 5ms	1A for 5ms
Fuse	1A	1A	2A	2A	2A
Maximum Break Torque Nm	20			20	15
Run & Reseat Torque Nm	15			15	
Manual operation	Yes, by hexagonal wrench (supplied in clip) when no power is being applied				
Run time	≈ 15 sec			≈ 10 sec	≈ 12 sec
<b>STANDARD FEATURES:</b>					
Operating frequency	Not continuous, allow ≥ 1 minute between cycles				
Position confirmation	Mechanically driven dome style visual 2 colour indicator				
Mounting restriction	None, can be mounted at any angle. Leave room for space to operate manually, and for electrical connection				
End Position indication	Micro-switches operated by adjustable internal cams , set slightly ahead of the final motor stop position.				
ISO:5211	F03 & F05 (+ F04 which mounts at 45 degrees)				
Working Angle	Factory set at 90° ±2°, maximum angle of rotation 360°				
Female drive	14mm Star (11mm octagon option) x 17mm deep				
Ingress protection	IP67, recommend cover provided if exposed to direct rain or sun				
Max media temp	≤ 80C				
Ambient temp	-20 to +60C (ABS) -20 to +80C (Aluminium)				
Non-operating temp	≤ -40C to ≥80C				
Ambient humidity	5-95% RH non-condensing				
Explosion proof	No, prohibited. Do not use in hazardous areas				
Housing	Plastic (ABS)				
Weight	With standard ABS housing 0.78kg (With optional aluminium housing 0.98kg)				
Options	Available failsafe using capacitor. See Model AVA-B24 for details				

TYPE: ACTUATED VALVES

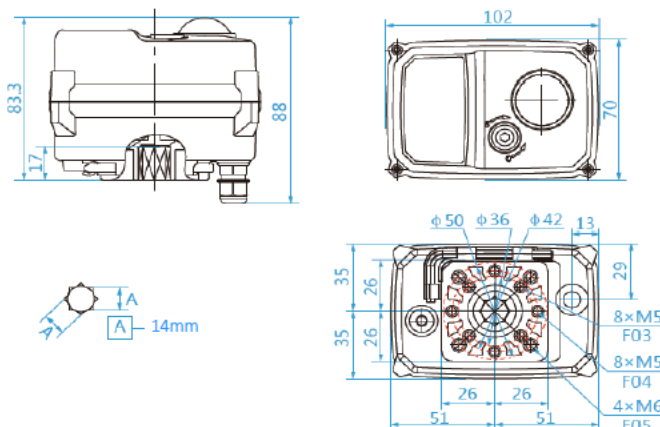

AVA actuators have various functions and specifications that changed based on voltage, therefore it makes it difficult to cover all specifications for all actuator models. We ask that you see our smart actuator section here for detailed information on actuator specifications including working times, power consumptions etc. For our Smart Actuators, we also offer a range of user guides and videos for the specific actuators.

ISO 9001:2015 Accredited Company

Tel: +44(0)1386 552369

Fax: +44(0)1386 554227

sales@allvalves.co.uk

www.allvalves.co.uk

Allvalves Online Ltd, Automation House, Unit 2, Pershore, WR10 2DF UK

### Wiring and Additional Technical Specifications:-

TYPE: ACTUATED VALVES

#### Actuator Details :-

AVA actuators have various functions and specifications that changed based on voltage, therefore it makes it difficult to cover all specifications for all actuator models. We ask that you see our smart actuator section here for detailed information on actuator specifications including working times, power consumptions etc. For our Smart Actuators, we also offer a range of user guides and videos for the specific actuators.

#### Local controls:



M button	M button is used to enter and switch menus.
K2 button	K2 is used in conjunction with K3 for adjusting values.
K3 button	K3 is used for changing settings, navigating menus, exiting and saving.
OLED Screen	OLED Screen with clear blue letters against a black background

AVA smart actuators use an OLED screen and touch button menu system allowing you to change the function of the actuator through changing settings in the software of the actuator. This varies per model, please see specific actuator series for full user guide and screen by screen instructions.

#### 9P-5.08 Terminal diagram

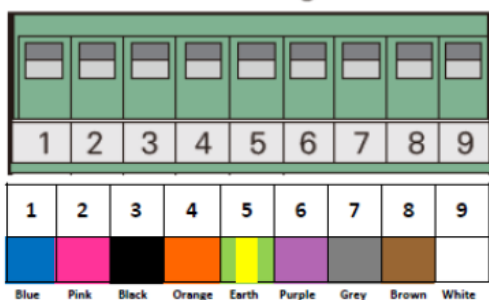

Our 60-110 series utilise a terminal strip, as shown above. The actuators as standard come with conduit entry 'Wiring Box', simply remove via 4 x screws and terminate your cable for power and feedback as required and as per the specific actuator wiring diagrams and IOMs'.

ISO 9001:2015 Accredited Company

Tel: +44(0)1386 552369

Fax: +44(0)1386 554227

sales@allvalves.co.uk

www.allvalves.co.uk

Allvalves Online Ltd, Automation House, Unit 2, Pershore, WR10 2DF UK