



Main Features:-

- ◆ Flanged PN16
- ◆ Stainless Steel Body, Cover & Disc
- ◆ Rated PN16
- ◆ Temperature -20°C to 180°C
- ◆ Also Available up to 12"

*Temperature and pressure determined by valve body, seat etc.

Suitable Applications & Approvals:



INDUSTRY

SERIES: 30154

MANUFACTURER: **AVOL**
INDUSTRIAL VALVES



Name	Material
Body	CF8M
Disc	CF8M
Nut	SS 304
Arm Hinge	CF8M
Hinge Pin	SS 316
Gasket	PTFE
Bolt	ASTM A194-2H
Bonnet	CF8M
Bolt	SS 304

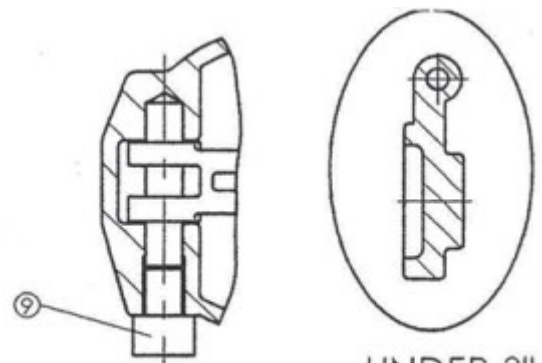
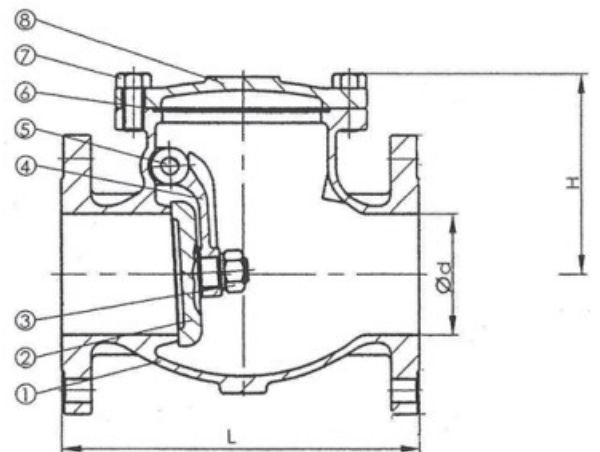

VALVE DIMENSIONS

Size	DN	d	L	H
1"	25	25	135	75
1 1/2"	40	40	165	107
2"	50	50	203	120
2 1/2"	65	65	216	135
3"	80	80	241	147
4"	100	100	292	169
6"	150	150	356	213

Test Pressure

Shell by Hydraulic	450PSI 32kg/cm ²
Seat by Hydraulic	315PSI 22kg/cm ²
Seat by Pneumatic	80PSI 6kg/cm ²



T +44 (0)1386 552369

E sales@allvalves.co.uk

W www.allvalves.co.uk

F +44 (0)1386 554227