



## Main Features:-

- ◆ Flanged BS EN 1092-2 PN16
- ◆ Blue Painted Ductile Iron Body
- ◆ Bronze Seat
- ◆ Rated PN16
- ◆ Temperature -10°C to 120°C

\*Temperature and pressure determined by valve body, seat etc.



## Suitable Applications & Approvals:



INDUSTRY

## SERIES: 30099

MANUFACTURER: **AVOL**  
INDUSTRIAL VALVES

### Name

### Materials

1	Body	Ductile Iron
2	Body Seat Ring	Copper Alloy
3	Door Seat Ring	Copper Alloy
4	Door	Ductile Iron
5	Bolt	Stainless Steel
6	Washer	Stainless Steel
7	Hanger	Ductile Iron
8	Gasket	EPDM
9	Inspection Cover	Ductile Iron
10	Washer	Stainless Steel
12	Gasket	PTFE
13	Air Release Plug	Stainless Steel
14	Std. Bush Nut	Copper Alloy
15	Bush Seal	EPDM
17	O'Ring	EPDM

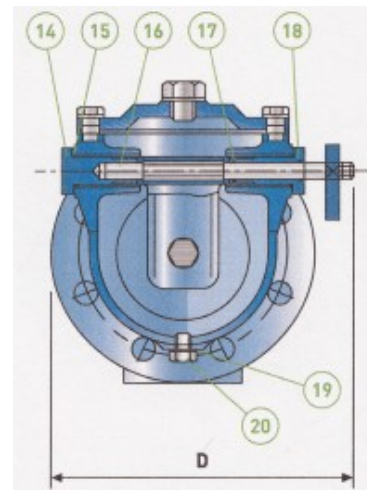
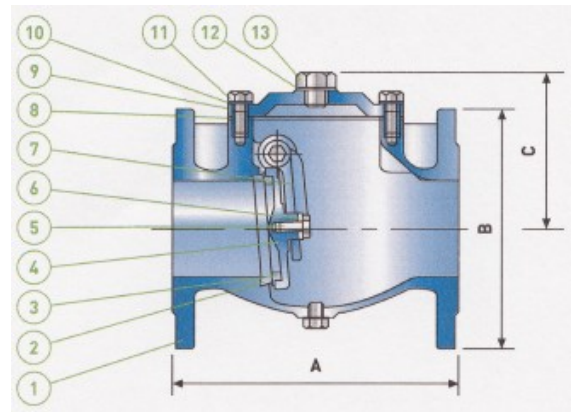

## VALVE DIMENSIONS

DN	A	B	C	D	Kg	Kg*
50	203	165	135	230	14	15
80	241	200	132	235	20	22
100	292	220	140	268	26	28
125	330	250	170	300	38	41
150	356	285	186	313	50	52
200	495	340	218	378	96	98
250	622	405	272	493	155	163
300	698	460	311	535	215	223
350	787	520	675	635	330	380
400	914	580	745	690	435	485

Kg\* represents weight with Lever & Weight



T +44 (0)1386 552369

E sales@allvalves.co.uk

W www.allvalves.co.uk

F +44 (0)1386 554227