



## Main Features:-

- ◆ Flanged PN16
- ◆ Encapsulated Wedge, Clockwise Closing
- ◆ Approved to GIS/V7-1:2007 and EN13774
- ◆ Maximum Pressure 16 Bar
- ◆ Temperature -20°C to 60°C

\*Temperature and pressure determined by valve body, seat etc.



## Suitable Applications & Approvals:



INDUSTRY

**SERIES: 30094**

MANUFACTURER: **AVOL**  
INDUSTRIAL VALVES

No	Name	Materials
1	Body	Ductile Iron
2	Bonnet	Ductile Iron
3	Wedge	NBR Encapsulated Ductile Iron
4	Wedge Nut	Dezincification Resistant Brass
5	Guide Shoe	Plastic
6	Stem	SS 420
7	Gland Bush	Dezincification Resistant Brass
8	Bonnet Gasket	NBR
9	O'Ring Seal	NBR
10	Dust Seal	NBR
11	Bonnet Screws	A2-70 SS
12	Bottom Washer	POM
13	Acetal Circlip	Plastic
14	Vent Plug	SS 420
15	Cap Top	Ductile Iron

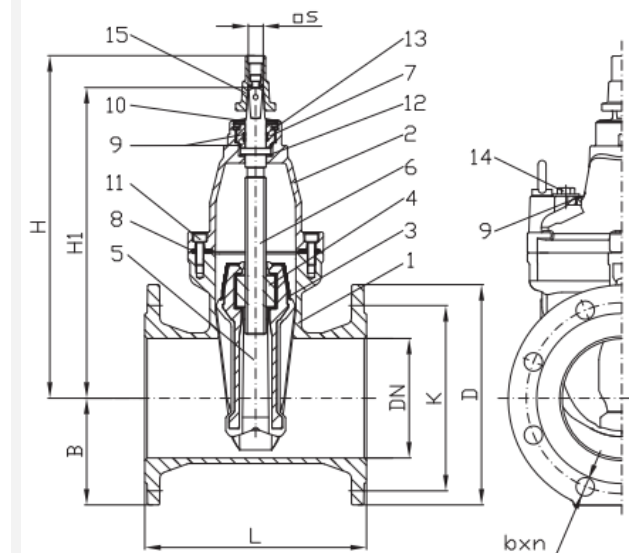

**VALVE DIMENSIONS**

Size	L	H1	H	B	K	b x n	D	S	Kv	Turns to close/open	Kg
2"	178	254	303	75	125	19x4	165	14.3	198	9 3/4	14.7
3"	203	265	308	95	160	19x8	200	17.3	654	11 1/2	18.6
4"	229	299	342	102	180	19x8	220	19.3	1252	14 1/4	21.6
6"	267	390	435	134	240	23x8	285	19.3	2818	20 1/4	39.3
8"	292	490	563	165	295	23x12	340	24.3	5601	18	65.3
10"	330	562	635	196	355	28x12	405	27.3	8751	21 3/4	88.6
12"	356	642	715	225	410	28x12	460	27.3	12602	26 1/3	137



**T** +44 (0)1386 552369

**E** sales@allvalves.co.uk

**W** www.allvalves.co.uk

**F** +44 (0)1386 554227