



Main Features:-

- ◆ Flanged PN16
- ◆ Bronze Body & Bonnet, PTFE Seat
- ◆ SDNR Rated PN16
- ◆ Temperature -10°C to 180°C
- ◆ Other Drillings Available

*Temperature and pressure determined by valve body, seat etc.

Suitable Applications & Approvals:



INDUSTRY



SERIES: 30059

MANUFACTURER: **AVOL**
INDUSTRIAL VALVES

VALVE DIMENSIONS

Name	Materials
Body	Bronze
Bonnet	Bronze
Disc	Bronze
Disc Nut	Bronze
Stem	High Tensile Brass
Gland Packing	Graphite
Gland	Bronze
Gland Nut	Bronze
Handwheel	Cast Iron
Washer	Mild Steel
Screw	Mild Steel

Size—DN	V	H	L
15	55	80	70
20	70	92	90
25	70	108	98
32	80	120	110
40	80	132	130
50	95	155	150
65	110	220	190
80	130	235	210
100	130	260	220

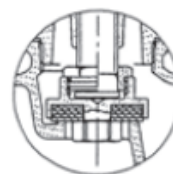
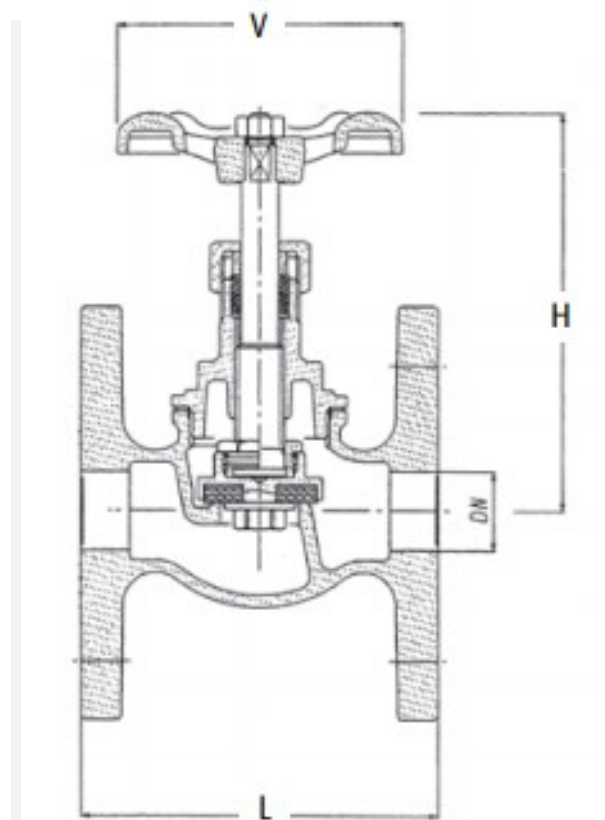

From DN15 to DN20

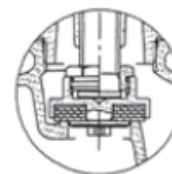

From DN65 to DN80

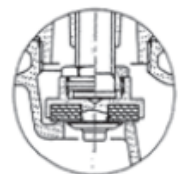

DN100



T +44 (0)1386 552369

E sales@allvalves.co.uk

W www.allvalves.co.uk

F +44 (0)1386 554227