



Main Features:-

- ◆ Screwed NPT, Full Bore
- ◆ WRAS Approved up to 2"
- ◆ Anti-blowout Stem
- ◆ Locking Device, Rated PN63
- ◆ Temperature -10°C to 180°C

*Temperature and pressure determined by valve body, seat etc.

Suitable Applications & Approvals:



INDUSTRY



SERIES: 10106

MANUFACTURER: **AVOL**
INDUSTRIAL VALVES

VALVE DIMENSIONS

No	Name	Materials
1	Body	CF8M
2	Cap	CF8M
3	Ball	CF8M
4	Ball Seat	PTFE
5	Joint Gasket	PTFE
6	Stem	316 SS
7	Thrust Washer	PTFE
8	Stem Packing	PTFE
9	Gland Nut	304 SS
10	Handle	430 SS
11	Spring Washer	304 SS
12	Stem Nut	304 SS
13	Handle Sleeve	Plastic
14	Locking Device	430 SS

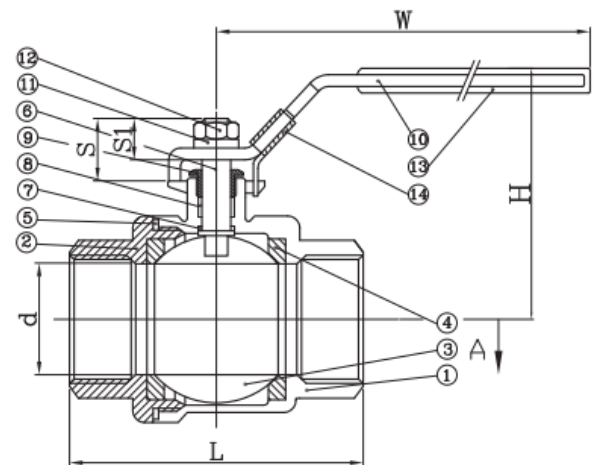

Pressure/ Temperature Chart

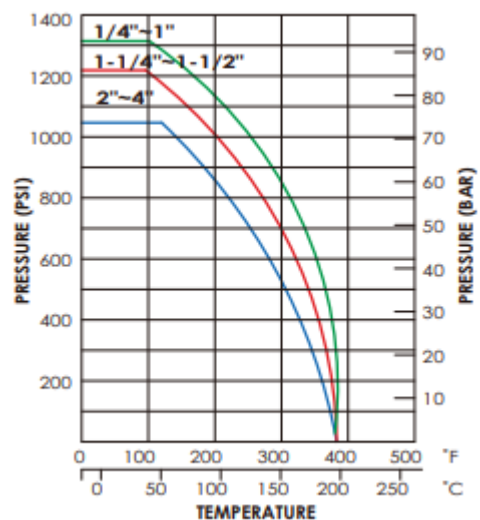

Size	d	L	H	W	S	S1	Kg
1/4"	11.6	50	48	91	16.5	16.5	0.22
3/8"	12.5	50	48	91	16.5	16.5	0.22
1/2"	15	60	52	91	16.5	16.5	0.29
3/4"	20	65	61	111	20	20	0.42
1"	25	80	65	111	23.5	23.5	0.71
1 1/4"	32	92	79	154	23.5	23.5	1.06
1 1/2"	38	105	83	154	25.5	25.5	1.68
2"	50	125	97	192	25.5	25.5	2.71
2 1/2"	64	155.6	129	246	41	41	5.25
3"	76	183	138	246	41	41	8.6
4"	96	240	175	317	51.2	51.2	19.32



T +44 (0)1386 552369

E sales@allvalves.co.uk

W www.allvalves.co.uk

F +44 (0)1386 554227