



## Main Features:-

- ◆ Butterfly Sanitary Valve
- ◆ Clamp ends in inches (BS 4825-3)
- ◆ Max. Working Pressure 10bar\*
- ◆ Max. Working Temperature 120C \*
- ◆ Body AISI 316L, EPDM Seat

\*Temperature and pressure determined by valve body, seat etc.



## SERIES: 80109

MANUFACTURER: **GENEBRE**

### Suitable Applications & Approvals:



HVAC



OIL



GAS



INDUSTRY

VALVE MATERIALS/DIMENSIONS

ITEM	SECTION	MATERIAL	ADDITIONAL INFO / OPTIONS
1	Body	SS 316L	Mechanical Polish
2	Seat	EPDM	-
3	Disc	SS 316L	Spare Part Code: E2940
4	Handle	SS 304	Mechanical Polish
5	Cap	Plastic	-
6	Bolt	SS 304	-
7	Nut	SS 304	-

REF	Size	DN	L	D	D1	H	L1	KxK	Kg
80109-06	1"	25	66	78	50.5	82	125	8x8	1.35
80109-08	1 1/2"	40	70	86	50.5	86	125	8x8	1.3
80109-09	2"	50	76	102	64	96	130	10x10	1.8
80109-10	2 1/2"	65	80	115	77.5	103	140	10x10	2.25
80109-11	3"	80	84	128	91	110	140	10x10	2.6
80109-12	4"	100	106	154	119	122	160	11x11	3.6

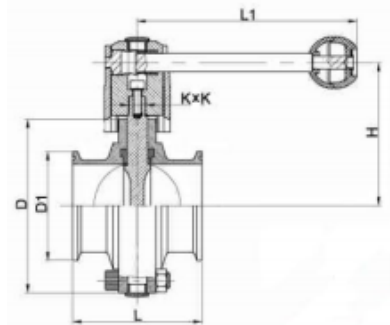
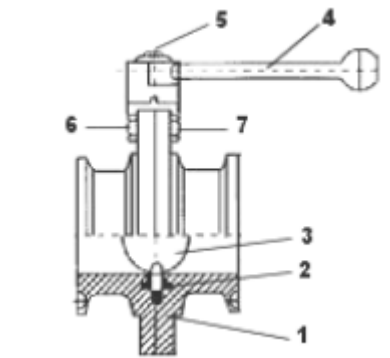

DN	100°	90°	80°	70°	60°	50°	40°	30°	20°	10°
25	19.8	14	12	11	8	6	5	4	2	1
40	48.5	40	32	24	20	11	9	5	4	1
50	91	75	61	48	34	24	15	10	5	1
65	142	95	90	80	54	35	30	14	6	4
80	205	150	100	95	86	60	40	21	11	5
100	372	340	290	250	195	140	75	38	25	10



T +44 (0)1386 552369

E sales@allvalves.co.uk

W www.allvalves.co.uk

F +44 (0)1386 554227