

Main Features:-

- ◆ Wafer type, full bore
- ◆ DN15 to DN100 PN16
- ◆ Blow – out proof stem
- ◆ Working Temperature –20 to + 180C *
- ◆ Ball seats PTFE + 15 % FG

*Temperature and pressure determined by valve body, seat etc.



SERIES: 80044

MANUFACTURER: **GENEBRE**

Suitable Applications & Approvals:



HVAC



OIL



GAS



INDUSTRY

VALVE MATERIALS & DIMENSIONS

ITEM	SECTION	MATERIAL	ADDITIONAL INFO / OPTIONS
1	Body	SS 1.4408	Shot Blasting + Pickling
2	Plug	SS 1.4408	Shot Blasting + Pickling
3	Gasket	PTFE	Spare Part Number 2818
4	Ball	SS 1.4408	n/a
5	Ball Seat	PTFE + 15 % F.V.	PTFE+15% FG
6	Stem	SS 316	n/a
7	Thrust Washer	PTFE	Spare Part Number 2818
8	O-Ring	FKM	Spare Part Number 2818
9	Packing	PTFE	Spare Part Number 2818
10	Gland	SS 304	n/a
11	Nut	SS 304	n/a

REF	SIZE	n x d	ØD	A	L	M	Kg
80044-04	1/2"	4 x M12	95	85	36	115	1.7
80044-05	3/4"	4 x M12	105	90	38	115	1.9
80044-06	1"	4 x M12	115	95	50	170	2.5
80044-07	1 1/4"	4 x M16	140	100	53	170	3.5
80044-08	1 1/2"	4 x M16	150	105	65	210	4.35
80044-09	2"	4 x M16	165	115	78	210	5.45
80044-10	2 1/2"	4 x M16	185	130	98	260	7.8
80044-11	3"	4 x M16	200	145	118	260	10.3
80044-12	4"	4 x M16	220	175	140	260	18

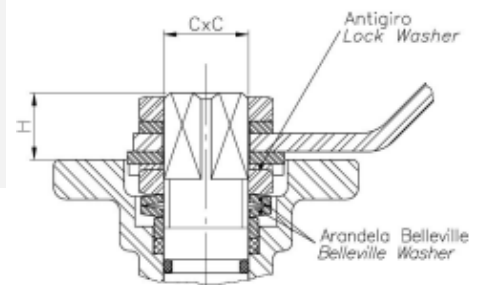
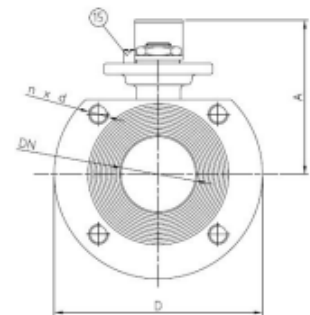
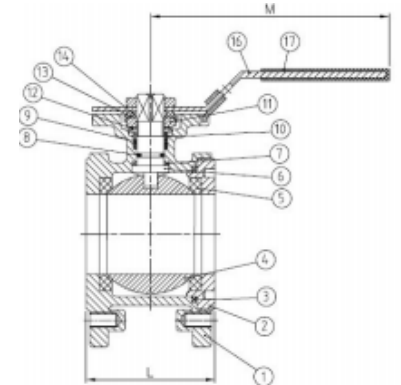

T +44 (0)1386 552369

E sales@allvalves.co.uk

W www.allvalves.co.uk

F +44 (0)1386



Genebre are a global brand of industrial valves with large stocks held for fast delivery on various type of valves, sizes, end connections and materials.

SERIES: 80044

TORQUE / Kv VALUES / PRESSURE & TEMP CHART

REF	SIZE	PN	H	CxC	ISO 5211
80044-04	1/2"	16	10	9x9	F03/F04
80044-05	3/4"	16	10	9x9	F03/F04
80044-06	1"	16	10	11x11	F04/F05
80044-07	1 1/4"	16	12.5	11x11	F04/F05
80044-08	1 1/2"	16	14.5	14x14	F05/F07
80044-09	2"	16	14	14x14	F05/F07
80044-10	2 1/2"	16	17	17x17	F07/F010
80044-11	3"	16	16	17x17	F07/F010
80044-12	4"	16	19	17x17	F07/F010

GENEBRE

Genebre is a leading company and world reference in fluid control and high-quality taps. They control all the creation processes, responding to the specific needs of each market: from the initial concept and design of the product to the production and commercialization.

REF	SIZE	TORQUE Nm	REF	SIZE	Kv
80044-04	1/2"		80044-04	1/2"	24
80044-05	3/4"		80044-05	3/4"	43
80044-06	1"		80044-06	1"	83
80044-07	1 1/4"		80044-07	1 1/4"	130
80044-08	1 1/2"		80044-08	1 1/2"	205
80044-09	2"		80044-09	2"	340
80044-10	2 1/2"		80044-10	2 1/2"	520
80044-11	3"		80044-11	3"	1100
80044-12	4"		80044-12	4"	1820

TORQUE :

- The liquid listed in the table are initial breakaway torques, taken with liquids and lubricant media.
- Please regard these as approximate values, as the

KV VALUES:

- The Kv values (M3 per hour) is the flow of water at a temperature of 5C to 30C (41F to 86F) at p of 1 bar

PRESSURE AND TEMPERATURE CHART

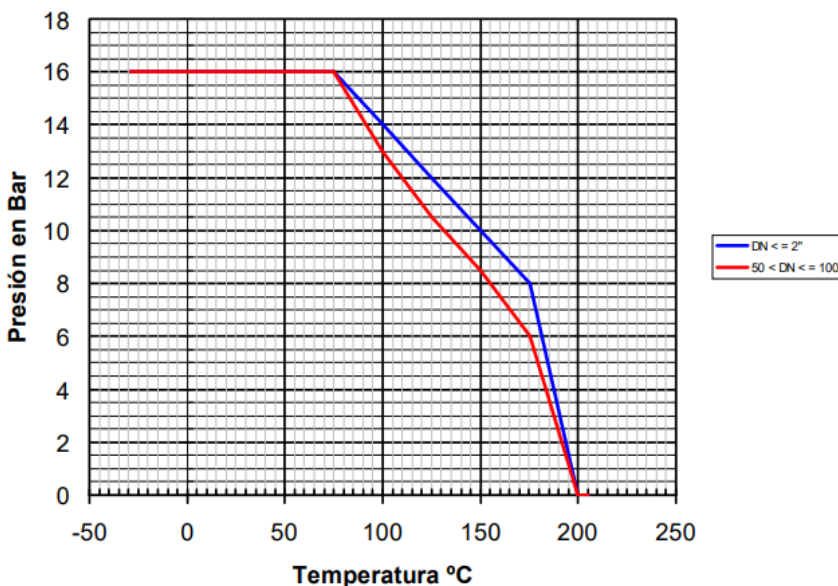

ALL VALVES

Offering a full range of actuated valve packages, manual valve range, pipe fittings and pumps, we have a product for all your requirements. As an ISO 9001-2015 Quality Approved and certified company, All Valves offer a quality service from pre-sale to post sale. Shipping millions of pounds in value of manual valve and actuated valve packages all over the world since its formation, All Valves are a trusted valve and actuator supplier to many companies all over the world. Working with the leading brands in most industries.



T +44 (0)1386 552369

E sales@allvalves.co.uk

W ww

F +44 (0)1386