



Main Features:-

- ◆ 2PC Full Port Ball Valve
- ◆ 1/4" to 3" PN63
- ◆ 80013-BSP, 80014-NPT
- ◆ Working Temperature -25 to +180C *
- ◆ Ball seats PTFE + 15 % G.F

*Temperature and pressure determined by valve body, seat etc.



Suitable Applications & Approvals:



HVAC



OIL



GAS



INDUSTRY

SERIES: 80013/80014

MANUFACTURER: **GENEBRE**

VALVE MATERIALS & DIMENSIONS

ITEM	SECTION	MATERIAL	ADDITIONAL INFO / OPTIONS
1	Ball	Stainless Steel 1.4408	Shot blasted
2	Cap	Stainless Steel 1.4408	Shot blasted
3	Ball	Stainless Steel 1.4408	Polishing
4	Stem	Stainless Steel AISI 316	n/a
5	Ball Seat	PTFE + 15 GF	n/a
6	Gasket	PTFE	n/a
7	Thrust Washer	PTFE	n/a
8	O Ring	FKM	n/a
9	Stem Packing	AISI 304	n/a
10	Washer	AISI 304	n/a
11	Nut	AISI 304	n/a
12	Handle	AISI 304	n/a

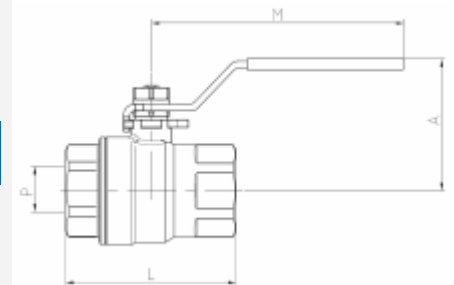
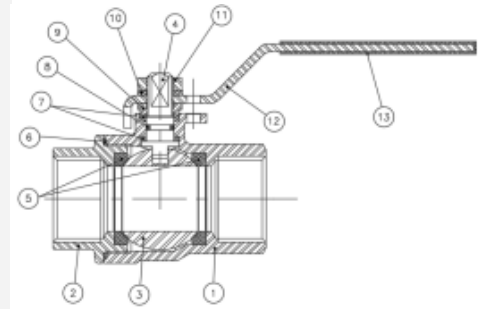

REF	SIZE	PN	P	A	L	M	Kg
80013-02*	1/4"	63	11	50	50	104	0.207
80013-03*	3/8"	63	12.7	50	50	104	0.195
80013-04*	1/2"	63	15	51.5	55	104	0.237
80013-05*	3/4"	63	20	62	70	122	0.442
80013-06*	1"	63	25	65	83	122	0.606
80013-07*	1 1/4"	63	32	82	91	180	1.084
80013-08*	1 1/2"	63	40	88	103	180	1.544
80013-09*	2"	63	50	106	120	219	2.648
80013-10*	2 1/2"	63	62	119	152	230	4.707
80013-11*	3"	63	76	135	172	274	7.288

* applies to 80013 and 80014



T +44 (0)1386 552369

E sales@allvalves.co.uk

W www.allvalves.co.uk

F +44 (0)1386 554227



Genebre are a global brand of industrial valves with large stocks held for fast delivery on various type of valves, sizes, end connections and materials.

SERIES: 80013/80014

TORQUE / Kv VALUES / PRESSURE & TEMP CHART

REF	SIZE	TORQUE Nm	REF	SIZE	Kv
80013-02	1/4"	4-5	80013-02	1/4"	6
80013-03	3/8"	4-5	80013-03	3/8"	10
80013-04	1/2"	4-5	80013-04	1/2"	24
80013-05	3/4"	7-8	80013-05	3/4"	43
80013-06	1"	9-10	80013-06	1"	83
80013-07	1 1/4"	12-14	80013-07	1 1/4"	130
80013-08	1 1/2"	18-20	80013-08	1 1/2"	205
80013-09	2"	28-30	80013-09	2"	340
80013-10	2 1/2"	34-36	80013-10	2 1/2"	520
80013-11	3"	58-60	80013-11	3"	1100

TORQUE :

- The liquid listed in the table are initial breakaway torques, taken with liquids and lubricant media.
- Please regard these as approximate values, as the objective value on different factors like pressure, medium, rubber

KV VALUES:

- The Kv values (M3 per hour) is the flow of water at a temperature of 5C to 30C (41F to 86F) at p of 1 bar

* applies to 80013 and 80014

PRESSURE AND TEMPERATURE CHART

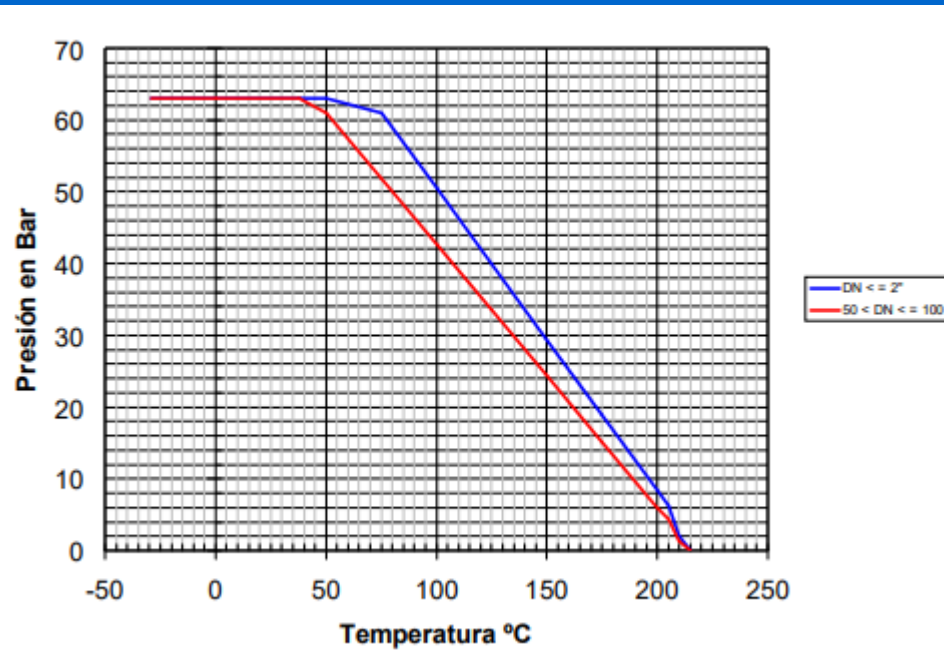

GENEBRE

Genebre is a leading company and world reference in fluid control and high-quality taps. They control all the creation processes, responding to the specific needs of each market: from the initial concept and design of the product to the production and commercialization.

In the Industrial line of Genebre products you will find a wide range of industrial valves and their accessories, sanitary line valves, automated valves and control valves, stainless steel fittings, different elements for industrial instrumentation and all spare parts for valves sphere.

